

HAUTE COUTURE
GLASS



SAVERGLASS

WINE COLLECTION VINS

**VINS
WINE**
COLLECTION

VINS TRANQUILLES / VINS EFFERVESCENTS
STILL WINES / SPARKLING WINES

PLACE DE LA GARE
60960 FEUQUIERES FRANCE
Tél. : +33 (0)3 44 46 45 45

www.saverglass.com



SAVERGLASS



SAVERGLASS

LE VERRE HAUTE COUTURE HAUTE COUTURE GLASS

SAVERGLASS EST LE SPÉCIALISTE MONDIAL DE LA FABRICATION ET DE LA DÉCORATION DE BOUTEILLES EN VERRE HAUT DE GAMME.

Reconnu pour son innovation, son expertise verrière et la qualité de ses produits et de leur design, SAVERGLASS est le partenaire privilégié des créateurs-vignerons et des plus grandes marques de vins fins, de champagne et de vins effervescents dans le monde.

LA RECHERCHE DE L'EXCELLENCE

L'excellence est une quête permanente. Chaque collaborateur du groupe porte ainsi individuellement une attention particulière à chaque détail, recherchant constamment la perfection. Au sein du groupe SAVERGLASS, aucun compromis n'est possible sur la qualité. Et cette exigence s'impose même au-delà des produits, à travers des objectifs d'amélioration continue : ne jamais se satisfaire, rechercher de nouvelles idées et développer sans cesse nos compétences.

LA PASSION DE LA CRÉATION

La passion pour la création, depuis plus de 30 ans, a conduit SAVERGLASS à placer le design au cœur de son organisation. Partie intégrante du patrimoine de l'entreprise, le design est un actif inestimable qui enrichit chaque année ses collections de formes innovantes, originales et créatrices de valeur. Ces créations sont le fruit du travail de ses designers, de sa veille permanente liée à l'évolution des marchés mais aussi d'une expertise unique acquise au travers des nombreux développements effectués sur l'ensemble des catégories de vins tranquilles et effervescents à travers le monde.

UNE OFFRE DE PRODUITS UNIQUE

Dans une optique de différenciation et de sophistication, l'entreprise donne naissance, depuis plusieurs décennies, à une offre de bouteilles de vin jouant sur des designs innovants, tout en créant un langage de formes totalement nouveau et imaginaire en rupture avec les codes traditionnels de l'emballage verrier (ex : piqûres singulières, bagues originales, épaulements géométriques, etc.). Ceux-ci vont répondre à la demande de premiumisation des vins haut de gamme et de luxe.

La collection proposée par SAVERGLASS représente aujourd'hui l'offre la plus large du marché des vins : 180 références qui se déclinent du format 18.7 cl au format 600 cl.

INNOVATION : UN ÉTAT D'ESPRIT

Dans un souci permanent d'améliorer la qualité des produits et des services proposés à ses clients, le groupe SAVERGLASS a développé une culture de l'innovation qui repose sur l'anticipation des grandes tendances au travers de solutions novatrices, fonctionnelles et créatrices de valeur.

Ainsi, 2 nouvelles innovations viennent enrichir l'éventail des solutions proposées par SAVERGLASS :

- **LA TRACABILITÉ** : sur un marché mondial des vins où les enjeux de qualité, de traçabilité et d'authentification se font croissants, SAVERGLASS propose une solution d'identification de chaque bouteille et de traçabilité de l'ensemble des composants et opérations ayant abouti à sa réalisation.

- **ART & TOUCH® by Saverglass** : SAVERGLASS invente une technologie innovante de parachèvement haute précision qui change la vision de la décoration en relief, ouvre le champ des possibles et marque le début d'une nouvelle ère dans la gravure de motifs tridimensionnels.

SAVERGLASS IS THE WORLD'S LEADING SPECIALIST IN THE MANUFACTURE AND DECORATION OF LUXURY GLASS BOTTLES.

Recognized for its innovation, its glassmaking expertise and the quality of its products and designs, SAVERGLASS is the partner of choice for creative wineries and the world's leading brands of fine wine, champagne and sparkling wine.

THE PURSUIT OF EXCELLENCE

Excellence is an ongoing quest. Each and every Group employee pays meticulous attention to detail, constantly seeking perfection. The SAVERGLASS Group makes no compromises when it comes to quality. This cornerstone of quality applies equally to aspects that are not specifically product-related in terms of ongoing improvement objectives: never being satisfied, seeking new ideas and constantly developing our expertise.

CREATIVE PASSION

For the past 30 years, our passion for creation has meant that SAVERGLASS puts design at the very heart of its organization. As an integral part of the company's heritage, design is an invaluable asset that each year enriches the company's collection of shapes that are innovative, original and add value.

These creations are the results of the work of the company's designers, its permanent monitoring of market trends coupled with its unique expertise gained through numerous developments carried out on all categories of still and sparkling wine bottles throughout the world.

A UNIQUE PRODUCT OFFERING

When it comes to differentiation and sophistication, the company has for decades produced wine bottles that play on innovative designs while creating a totally new and imaginative language of shapes that break with the traditional codes of glass packaging (e.g. distinctive punt shapes, innovative finishes, geometric shoulders, etc.). This approach meets the demand for premium packaging design in high-end and luxury wines. The SAVERGLASS collection is the largest offering in the wine market: 180 products are available in formats ranging from 18.7cl to 600cl.

INNOVATION: A STATE OF MIND

In order to keep on improving the quality of its products and services for its customers, the SAVERGLASS Group has developed a culture of innovation, constantly staying one step ahead of major trends and providing solutions that are innovative, functional and add value.

Two new innovations recently enriched the range of solutions offered by SAVERGLASS:

- **TRACEABILITY**: in a global wine market where issues of quality, traceability and authentication are ever more important, SAVERGLASS offers technology to identify each bottle and trace all components and operations leading to its production.

- **ART & TOUCH® by Saverglass**: SAVERGLASS has invented an innovative high-precision finishing technology that changes the vision of relief decoration, opens up the field of possibilities and marks the beginning of a new era in the engraving of three-dimensional motifs.



CHIFFRES CLÉS

GROUPE

GROUP KEY FIGURES

PRODUCTION
PRODUCTION

500 000
TONNES PAR AN
TONS PER YEAR



700 MILLIONS DE BOUTELLES
MILLION BOTTLES

150 DONT
MILLIONS DE BOUTELLES DÉCORÉES
INCLUDING
MILLION DECORATED BOTTLES

5 SITES DE PRODUCTION
VERRE
GLASS FACTORIES



FRANCE
FEUQUIÈRES (60)
LE HAVRE (76)
ARQUES (62)

ÉMIRATS ARABES UNIS
RAS AL KHAIMAH

MEXIQUE
ACATLAN DE JUAREZ
(JALISCO)

4 SITES DE
DÉCORATION
DECORATION FACTORIES



FRANCE
FEUQUIÈRES (60)
ARQUES (62)
COULOMMIERS (77)

MEXIQUE
ACATLAN DE JUAREZ
(JALISCO)

COLLABORATEURS
PEOPLE

3000
COLLABORATEURS
PEOPLE



CRÉATION
CREATION

1897 FEUQUIÈRES, FRANCE

CHIFFRE D'AFFAIRES
TOTAL SALES

428 M€
514 M\$
EN
IN 2017

RÉPARTITION PAR ACTIVITÉ
SALES VOLUME PER ACTIVITY



SPIRITUEUX
55%
SPIRITS



VINS &
CHAMPAGNES
42%
STILL &
SPARKLING
WINES



PARFUMERIE &
COSMÉTIQUES
3%
PERFUMES &
COSMETICS

IMPLANTATIONS
LOCATION

50%
DU CA
RÉALISÉ À L'EXPORT
OF TOTAL SALES
COMING FROM EXPORT

PRÉSENT À L'EXPORT DANS PLUS DE
EXPORTING IN MORE THAN

80 PAYS
COUNTRIES

REPOSANT SUR UN RÉSEAU DE
BASED ON A NETWORK OF

17 FILIALES
AU NIVEAU MONDIAL

SUBSIDIARIES WORLDWIDE



■ USINES, FILIALES & BUREAUX
FACTORIES, SUBSIDIARIES & OFFICES

DOMAINES D'ACTIVITÉ

BUSINESS SECTORS



VINS TRANQUILLES
& EFFERVESCENTS
STILL & SPARKLING WINES



SPIRITUEUX
SPIRITS

4
DOMAINES
D'ACTIVITÉ
4 BUSINESS SECTORS



PARFUMERIE & COSMÉTIQUE
PERFUMERY & COSMETICS



ALIMENTAIRE
FOOD PRODUCTS

AVANTAGES CLÉS

KEY ADVANTAGES

VERRIER + DÉCORATEUR
GLASS MANUFACTURER + DECORATOR

1 La **complémentarité** nécessaire à la réalisation de vos projets les plus exigeants
The **expertise** for your most demanding projects

2

Un **dispositif industriel**
verrier important
An **important industrial** glass
manufacturing system



Verre nu
Plain glass

**UN SERVICE
COMPLÉT**
A COMPLETE
CUSTOMER SERVICE

3

Une **activité de
parachèvement**
conséquence
An **extensive
decoration activity**



Produit fini décoré
Finished and
decorated product



DESIGN

À la fois capteur et créateur de tendances, SAVERGLASS s'impose d'être en tête en matière de créativité sur le segment de la bouteillerie de luxe. Créer, Oser, Innover et Séduire sont les maître mots qui inspirent les réflexions et les décisions de notre cellule marketing. Nouvelles formes verrières, nouveaux procédés de personnalisation ou de parachèvement, nouvelles solutions d'accessoirisation, tels sont les thèmes explorés sans relâche.

With its finger on the design pulse and constantly seeking new solutions, SAVERGLASS has established itself as creative leader in the luxury bottle segment. Create, Dare, Innovate and Seduce are the keywords that inspire the work of our marketing department. They are relentlessly exploring new glass forms, new personalisation and finishing procedures, and new accessorisation solutions.

COLLECTION EXTRA LARGE

**UN CATALOGUE PROPOSANT
PLUS DE 100 MODÈLES MDDS***
DÉDIÉS AUX VINS TRANQUILLES
ET EFFERVESCENTS

L'offre globale de SAVERGLASS :

- Des gammes profondes et cohérentes : des produits avec une même silhouette, un même dessin d'épaule pour un standing et un poids de verre différent.
- Une grande diversité des contenances : 18.7 cl, 20 cl, 37.5 cl, 50 cl, 75 cl, 150 cl, 300 cl, 500 cl, 600 cl.
- Un large choix de bagues : Plate FA, Plate Unique, BVS...

*MDDS : Modèles Déposés Design SAVERGLASS



**MORE THAN 100 PROPRIETARY
SPECIALITY SAVERGLASS DESIGNS
DEDICATED TO THE WINE INDUSTRY**

The overall supply of SAVERGLASS:

- Deep ranges: products with the same silhouette, same shoulder's drawing for a different glass weight and standing.
- A wide choice of ranges and sizes: 18.7cl, 20cl, 37.5cl, 50cl, 75cl, 150cl, 300cl, 500cl, 600cl.
- Lots of different finishes : Plate FA, Plate Unique, BVS...

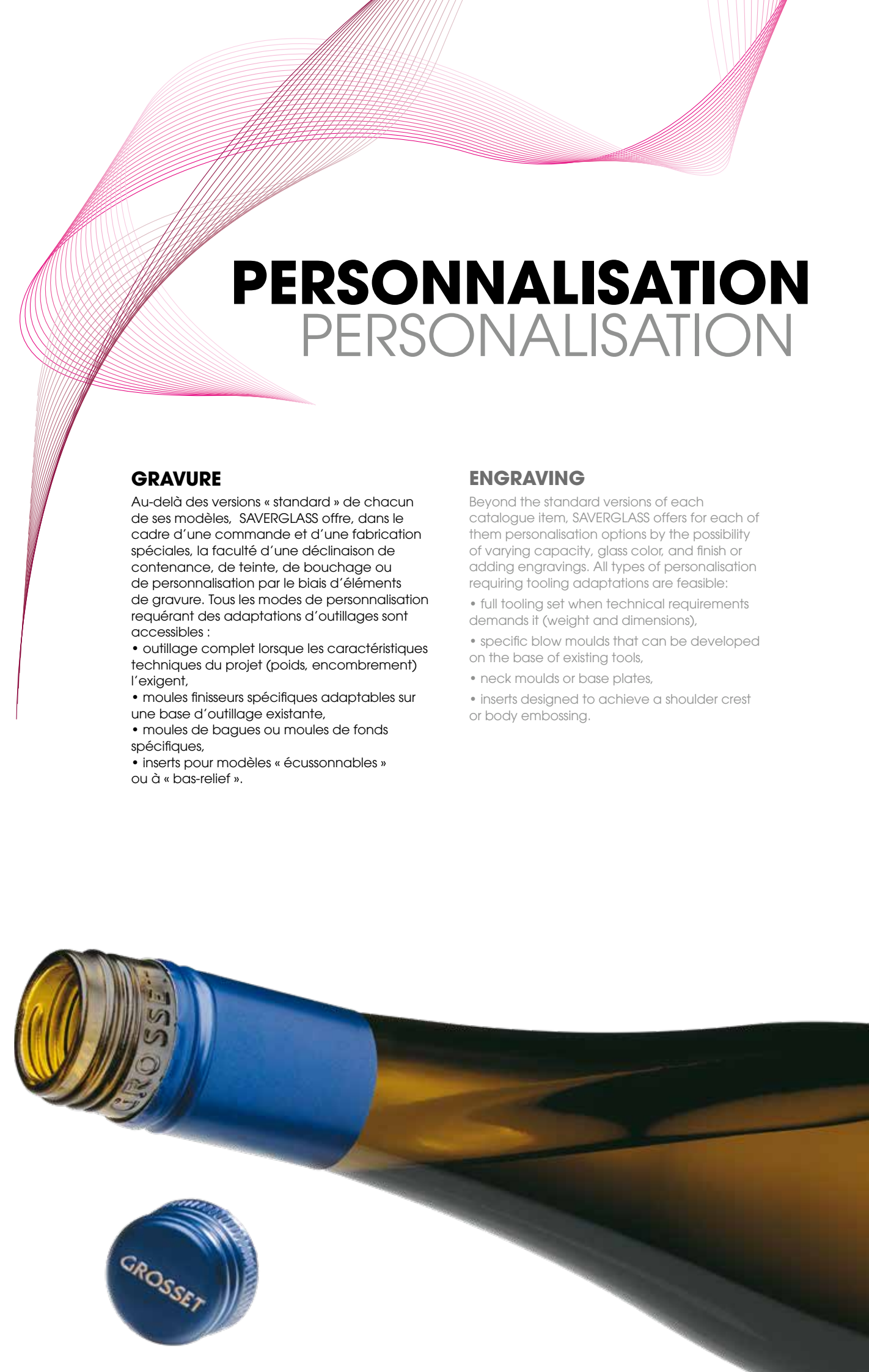

PERSONNALISATION PERSONALISATION

GRAVURE

Au-delà des versions « standard » de chacun de ses modèles, SAVERGLASS offre, dans le cadre d'une commande et d'une fabrication spéciales, la faculté d'une déclinaison de contenance, de teinte, de bouchage ou de personnalisation par le biais d'éléments de gravure. Tous les modes de personnalisation requérant des adaptations d'outillages sont accessibles :

- outillage complet lorsque les caractéristiques techniques du projet (poids, encombrement) l'exigent,
- moules finisseurs spécifiques adaptables sur une base d'outillage existante,
- moules de bagues ou moules de fonds spécifiques,
- inserts pour modèles « écussonnables » ou à « bas-relief ».

ENGRAVING

Beyond the standard versions of each catalogue item, SAVERGLASS offers for each of them personalisation options by the possibility of varying capacity, glass color, and finish or adding engravings. All types of personalisation requiring tooling adaptations are feasible:

- full tooling set when technical requirements demands it (weight and dimensions),
- specific blow moulds that can be developed on the base of existing tools,
- neck moulds or base plates,
- inserts designed to achieve a shoulder crest or body embossing.

COLORATION FEEDER



JADE
GREEN

MOKA

WATER
GREEN

MIEL

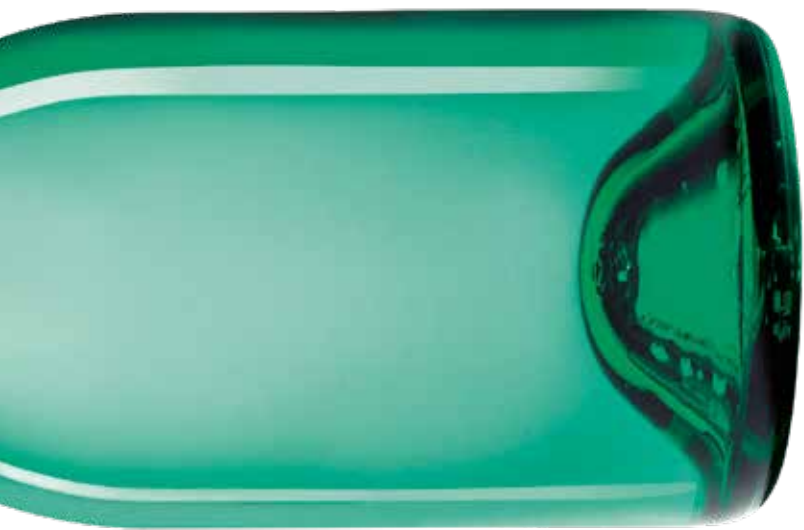
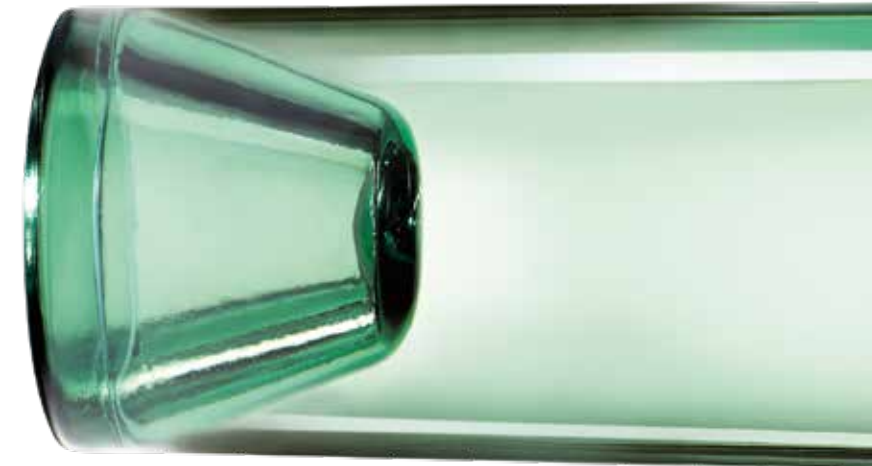

LES SELECT COLORS®

- Une collection originale de 4 teintes de verre à vocation vins tranquilles ou effervescents, teintées dans la masse.
- Une nouvelle donne créative en matière de bouteille haut de gamme.

DES TEINTES SPÉCIFIQUES

- La possibilité de créer votre propre teinte.
- Un seuil quantitatif de 300 000 cols minimum par série de fabrication.

SELECT COLORS® BY SAVERGLASS

- An original collection of 4 shades colored in bulk, dedicated to still & sparkling wines.
- A new creative deal in the field of upmarket bottleware.

SPECIFIC COLORS

- The possibility to create your own color.
- 300,000 bottles minimum for each manufacturing batch.

DÉCORATION DECORATION

PRINCIPAUX PROCÉDÉS
A LARGE CHOICE OF DECORATION PROCESSES



SATINAGE
ACID-ETCHING

SÉRIGRAPHIE
SCREEN PRINTING
ENCRE ORGANIQUE
ORGANIC INK



SÉRIGRAPHIE
SCREEN PRINTING
MÉTAUX PRÉCIEUX
PRECIOUS METALS

SAVERCOAT®
VERNIS HYDROSOLUBLE
WATER-SOLUBLE VARNISH

BORDELAISES



BOURGOGNES



VINS WINE COLLECTION

NOUVEAUX CONCEPTS NEW CONCEPTS



COLLECTION BVS



VINS EFFERVESCENTS SPARKLING WINES



VINS TRANQUILLES STILL WINES

BORDELAISES

ORIGINAL
DESIGN

BORDELAISE 1855	22
BORDELAISE CONSTANCE SUPERBIA . . .	24
BORDELAISES GRANDS CRUS CLASSÉS . .	26
BORDELAISES HERMÈS & MERCURE	28
BORDELAISE ALIÉNOR	30
BORDELAISES APPARAT & CORPORATE . .	32
BORDELAISE BELLISSIMA WINE	34
BORDELAISE BYBLOS	36
BORDELAISE CONSTANCE	38
BORDELAISE ICARO	40
BORDELAISES PERSONNALISÉES	42
BORDELAISE SAINT-PIERRE	44
BORDELAISES CONIQUES	46
BORDELAISE SIGNATURE	48

PREMIUM
DESIGN

BORDELAISE ANCIENNE	50
BORDELAISE CAPRI	52
BORDELAISE CAUDALIE	54
BORDELAISE EDEN	56
BORDELAISE MAESTRIA	58
LES PORTO	60
BORDELAISE RIVIERA	62
BORDELAISE ANCIENNE 2	64
BORDELAISE SANTIAGO	66

CLASSIC
DESIGN

BORDELAISE BAMBOO WINE	68
BORDELAISES CAPRICE & CHÂTEAU . . .	70
CLASSIC BORDELAISE	72
BORDELAISES PREMIÈRE	74
BORDELAISES TRADITION	76

BOURGOGNES

ORIGINAL
DESIGN

BOURGOGNE 1859	82
BOURGOGNES IMPÉRIALES	84
BOURGOGNE BOURGEOISE	86
BOURGOGNE CÉLESTE	88
BOURGOGNE MAXIMA	90
BOURGOGNE SABINE	92
BOURGOGNES TENDANCE	94
BOURGOGNES PERSONNALISÉES	96
BOURGOGNES CHARDONNAY & ATLAS . .	98

PREMIUM
DESIGN

BOURGOGNE GRAVILLE	100
BOURGOGNE JUSTINE	102
BOURGOGNE TASTEVINE	104
BOURGOGNE VIN GRAND CRU	106

CLASSIC
DESIGN

BOURGOGNES CÉPAGE & AGAPE	108
BOURGOGNE ÉLÉGANCE	110
BOURGOGNE GRAND MILLÉSIME	112
BOURGOGNES PRESTIGE	114
BOURGOGNES TRADITION	116

NOUVEAUX CONCEPTS NEW CONCEPTS

ORIGINAL
DESIGN

ESSENCIA WINE	122
FENG WINE	124
GEISHA WINE	126
KENDO WINE	128
MASSALIA	130
SOPHIA	132
THEOS WINE	134
BORDELAISES ÉCLAT	136
CONCEPT INVENT	138

PREMIUM
DESIGN

CONCEPT ANTIK	140
-------------------------	-----

FLÛTES HOCKS

ORIGINAL
DESIGN

FLÛTES ALLEGRO	146
FLÛTES ALTUS	148

CLASSIC
DESIGN

FLÛTES ALTUS WINE	150
FLÛTES TRADITION	152
FLÛTES VIN CLUB	154

COLLECTION BVS

BORDELAISES BVS	158
BOURGOGNES BVS	160
FLÛTES BVS	162

BORDELAISES

ORIGINAL DESIGN

BORDELAISE 1855	22
BORDELAISE CONSTANCE SUPERBIA ..	24
BORDELAISES GRANDS CRUS CLASSÉS	26
BORDELAISES HERMÈS & MERCURE ...	28
BORDELAISE ALIÉNOR	30
BORDELAISES APPARAT & CORPORATE	32
BORDELAISE BELLISSIMA WINE	34
BORDELAISE BYBLOS	36
BORDELAISE CONSTANCE	38
BORDELAISE ICARO	40
BORDELAISES PERSONNALISÉES	42
BORDELAISE SAINT-PIERRE	44
BORDELAISES CONIQUES	46
BORDELAISE SIGNATURE	48

PREMIUM DESIGN

BORDELAISE ANCIENNE	50
BORDELAISE CAPRI	52
BORDELAISE CAUDALIE	54
BORDELAISE EDEN	56
BORDELAISE MAESTRIA	58
LES PORTO	60
BORDELAISE RIVIERA	62
BORDELAISE ANCIENNE 2	64
BORDELAISE SANTIAGO	66

CLASSIC DESIGN

BORDELAISE BAMBOO WINE	68
BORDELAISES CAPRICE & CHÂTEAU ..	70
CLASSIC BORDELAISE	72
BORDELAISES PREMIÈRE	74
BORDELAISES TRADITION	76

BORDELAISE 1855

EXTRA PREMIUM



Authentique « bouteille d'époque », la Bordelaise **1855** reproduit la forme originelle de la bouteille de Bordeaux. Elle restitue cet équilibre parfait entre le col, la bague, la silhouette conique et la piqûre très profonde au plan de pose étroit et lisse. Ne se prêtant à aucune des concessions esthétiques de la production industrielle, la Bordelaise **1855** élève cette bouteille de vin au statut de flacon de luxe.

An authentic "vintage bottle", the Bordelaise **1855** reproduces the shape of the original Bordeaux bottle. It offers slim smooth lines with a deep punt and a perfectly balanced neck and finish. Making none of the aesthetic concessions usual in industrial production, the Bordelaise **1855** elevates this wine bottle to the status of a luxury flask.

BORDELAISE
1855

EXTRA PREMIUM

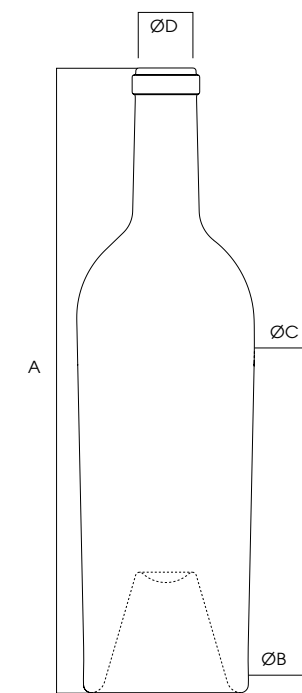

BORDELAISE 1855



BORDELAISE 1855
À CRAN / WITH NOTCH

		75 cl	75 cl
CONTENANCE CAPACITY		75 cl	75 cl
RÉFÉRENCE REFERENCE		3817 ©	4003 ©
BAGUE FINISH		 Bague Plate SB29.5 Plate SB29.5 Finish	 Bague Plate SB 29.5 Plate SB29.5 Finish
POIDS WEIGHT	(g)	760	760
HAUTEUR TOTALE TOTAL HEIGHT	A (mm)	300.5	300.5
Ø PIED BASE Ø	B (mm)	79.4	79.4
Ø ÉPAULE SHOULDER Ø	C (mm)	84.8	84.8
Ø DÉBOUCHAGE ENTRANCE BORE	D (mm)	18.5	18.5
TEINTE GLASS COLOUR		● ○ ¹	● ○ ¹

○ : Extra Blanc / Extra White Flint ● : Antique / Antique Green ¹ : Sur commande / To order

© : Modèle déposé "Design Saverglass" / © : Registered "Design Saverglass"

BORDELAISE CONSTANCE SUPERBIA

EXTRA PREMIUM



D'inspiration bordelaise, **CONSTANCE SUPERBIA** séduit par sa silhouette gracile. Sa légère conicité couplée à un épaulement charnu dessine avec élégance une bouteille au profil généreux et statutaire. Mais c'est sa piqûre profonde qui l'inscrit définitivement dans la catégorie des flacons « à part » et uniques, imaginés pour sublimer de précieux contenus, fruits du travail de toute une année.

Inspired by the Bordelaise, **CONSTANCE SUPERBIA** seduces with its graceful silhouette. Its slightly tapered shape coupled with a strong shoulder produce a bottle with a generous and statuesque elegance. But it is the deep punt that places it definitively in the category of "different class" and unique flasks, created to enhance its precious content, **CONSTANCE SUPERBIA** is the fruit of an entire year's design work.

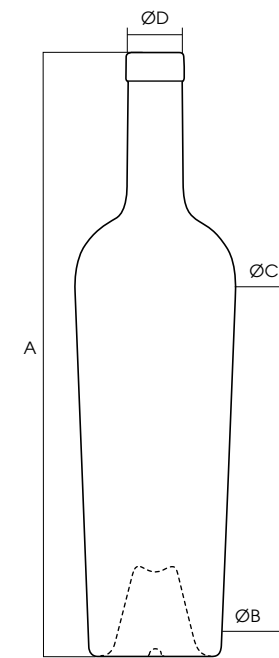



BORDELAISE
**CONSTANCE
SUPERBIA**
EXTRA PREMIUM
ORIGINAL DESIGN



CONSTANCE
SUPERBIA



CONSTANCE
SUPERBIA

CONTENANCE CAPACITY		75 cl	75 cl
RÉFÉRENCE REFERENCE		5020 ©	5020 ©
BAGUE FINISH		 Bague Plate FA Plate FA Finish	 Bague Carrée Bourgogne Classique Carrée Bourgogne Classique Finish
POIDS WEIGHT	(g)	1200	1200
HAUTEUR TOTALE TOTAL HEIGHT	A (mm)	333.6	334
Ø PIED BASE Ø	B (mm)	73.3	73.3
Ø ÉPAULE SHOULDER Ø	C (mm)	88.9	88.9
Ø DÉBOUCHAGE ENTRANCE BORE	D (mm)	18.5	18.5
TEINTE GLASS COLOUR		●	●

● : Antique / Antique Green

© : Modèle déposé "Design Saverglass" / © : Registered "Design Saverglass"

BORDELAISES GRANDS CRUS CLASSÉS

EXTRA PREMIUM



BORDELAISES
GRANDS CRUS
CLASSÉS
EXTRA PREMIUM
ORIGINAL
DESIGN



ALEKA PARADIS GRAND APPARAT VINO SANTO

Composée de flacons d'exception, la gamme Bordelaises **GRANDS CRUS CLASSÉS** réinterprète, avec générosité, les lignes aristocratiques des bouteilles d'époque. Caractérisés par leur piqûre ultra profonde et leur imposante bague carrée, les modèles de la gamme Bordelaises **GRANDS CRUS CLASSÉS** dévoilent des silhouettes fières et sculpturales au service du prestige des plus grands vins.

Par son poids de verre extrême de 1200 g et la puissance de sa silhouette, la Bordelaise **VINO SANTO** se positionne dans la catégorie « extra premium » des flacons d'exception. Une ligne élan-cée, un fût cylindrique, un rayon de jable nerveux et un col court surmonté d'une imposante bague constituent les points de singularité les plus remarquables de **VINO SANTO**.

Consisting of exceptional flasks, the **GRANDS CRUS CLASSÉS** Bordeaux range generously reinterprets the aristocratic lines of vintage bottles. Characterized by their ultra-deep punt and imposing square finishes, the models in the **GRANDS CRUS CLASSÉS** Bordeaux range unveil proud, sculptured silhouettes to match the prestige of the greatest wines.

With its extremely heavy 1,200g glass weight and striking shape, the **VINO SANTO** is definitely in the «extra-premium» category of exceptional flasks. Sleek lines, a cylindrical base, a racy heel diameter, and a short neck mounted on an imposing finish are the most distinctive features of **VINO SANTO**.



CONTENANCE CAPACITY		75 cl	75 cl	75 cl	75 cl
RÉFÉRENCE REFERENCE		3638 ©	3441 ©	4308 ©	4342
BAGUE FINISH		 Bague Carrée Bourgogne Classique Carrée Bourgogne Classique Finish	 Bague Carrée Bourgogne Classique Carrée Bourgogne Classique Finish	 Bague Plate SB30 Plate SB30 Finish	 Bague Carrée Bourgogne Classique Carrée Bourgogne Classique Finish
POIDS WEIGHT	(g)	1200	840	1200	1203
HAUTEUR TOTALE TOTAL HEIGHT	A (mm)	325.8	311	315.8	330.5
Ø PIED BASE Ø	B (mm)	80.3	77.7	85.3	82.7
Ø ÉPAULE SHOULDER Ø	C (mm)	87.6	84.7	85.3	82.7
Ø DÉBOUCHAGE ENTRANCE BORE	D (mm)	18.5	18.5	18.5	18.5
TEINTE GLASS COLOUR		●	● ○	●	●

○ : Extra Blanc / Extra White Flint ● : Antique / Antique Green

© : Modèle déposé "Design Saverglass" / © : Registered "Design Saverglass"

BORDELAISES HERMÈS & MERCURE

EXTRA PREMIUM

ORIGINAL
DESIGN



Charismatique, la Bordelaise **HERMÈS** captive par sa beauté classique et son élégant équilibre des proportions. Dotée d'un poids de verre de 1000 g, elle affiche une bague carrée, une épaule galbée et une piqûre profonde qui participent à l'image statutaire et à la prestance du modèle.

La Bordelaise **MERCURE** impose sa silhouette statutaire et puissante, non sans lien de parenté avec le modèle HERMÈS. Elle se caractérise par le galbe de son épaule et sa profonde piqûre ainsi qu'un poids de verre exceptionnel de 1200 g. Ce qui lui permettra d'accompagner magistralement les crus les plus prestigieux.

The classic beauty and elegantly balanced proportions of the charismatic Bordelaise **HERMÈS** are captivating. Weighing 1,000g, it boasts a square finish, a sloped shoulder and a deep punt that all contribute to the statuesque poise of this model.

The Bordelaise **MERCURE** stands out due to its statuesque, powerful shape, with a definite family resemblance to the HERMÈS. It is characterized by its sloped shoulder and its deep punt as well as the exceptional 1,200g glass weight, masterfully enhancing the most prestigious vintages.

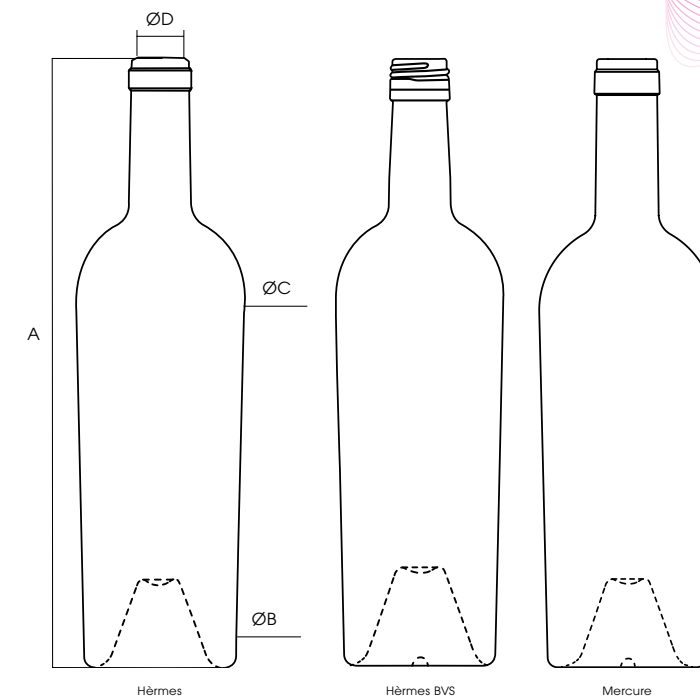

BORDELAISES
HERMÈS &
MERCURE
EXTRA PREMIUM

ORIGINAL
DESIGN





HERMÈS



HERMÈS BVS



MERCURE

CONTENANCE CAPACITY	75 cl	75 cl	75 cl
RÉFÉRENCE REFERENCE	2998 ©	4048 © Sur commande To order	5367 ©
BAGUE FINISH	 Bague Carrée Bourgogne Classique Carrée Bourgogne Classique Finish	 Bague BVS 31.5H60 BVS 31.5H60 Finish	 Bague Plate SB31 Plate SB31 Finish
POIDS WEIGHT (g)	992	998	1197
HAUTEUR TOTALE TOTAL HEIGHT A (mm)	312.3	312.3	312
Ø PIED BASE Ø B (mm)	77.8	77.8	81.4
Ø ÉPAULE SHOULDER Ø C (mm)	86.3	86.3	90.1
Ø DÉBOUCHAGE ENTRANCE BORE D (mm)	18.5	20	17.5
TEINTE GLASS COLOUR	●	●	● ¹

● : Antique / Antique Green ¹ : Sur commande / To order

© : Modèle déposé "Design Saverglass" / © : Registered "Design Saverglass"

BORDELAISE ALIÉNOR

SUPER PREMIUM



Telle Aliénor d'Aquitaine, illustre reine médiévale, **ALIÉNOR** s'impose comme la digne héritière de la culture bordelaise. Épaule caractéristique « Saint-Émilion », fût tronconique et piqûre très profonde munie d'une boudine pensée pour faciliter le service du sommelier, la gamme reprend tous les signes distinctifs des flacons d'autrefois.

Like Eleanor of Aquitaine, the famous medieval queen, **ALIÉNOR** stands out as a worthy heir to Bordeaux culture. With its characteristic "Saint-Émilion" shoulder, trunk-like base and very deep punt with a "boudine" designed to help the sommelier serve from it, the range boasts all the distinctive marks of vintage bottles.

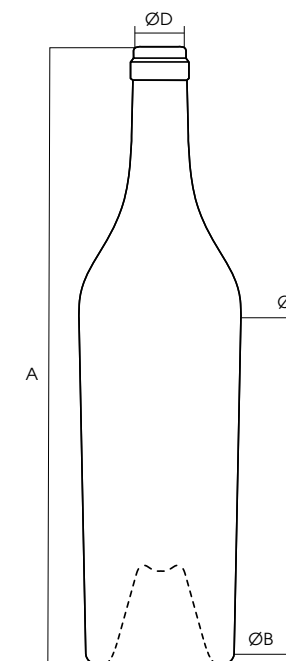



BORDELAISE
ALIÉNOR
SUPER PREMIUM
ORIGINAL DESIGN



ALIÉNOR

ALIÉNOR

CONTENANCE CAPACITY		50 cl	75 cl
RÉFÉRENCE REFERENCE		3329 ©	2260 ©
BAGUE FINISH		 Bague Plate Unique Plate Unique Finish	 Bague Plate Unique Plate Unique Finish
POIDS WEIGHT	(g)	600	765
HAUTEUR TOTALE TOTAL HEIGHT	A (mm)	288	313.7
Ø PIED BASE Ø	B (mm)	67	77.5
Ø ÉPAULE SHOULDER Ø	C (mm)	72	83.5
Ø DÉBOUCHAGE ENTRANCE BORE	D (mm)	18.5	18.5
TEINTE GLASS COLOUR		● ○	●

○ : Extra Blanc / Extra White Flint ● : Antique / Antique Green

© : Modèle déposé "Design Saverglass" / © : Registered "Design Saverglass"

BORDELAISES APPARAT & CORPORATE

SUPER PREMIUM

ORIGINAL DESIGN



Puisant son inspiration parmi les bouteilles bordelaises anciennes, le modèle **APPARAT** revisite les lignes d'autrefois avec une véritable exigence d'authenticité. Affichant une silhouette plantureuse, **APPARAT** se caractérise par un jable de tout petit rayon et une piqûre profonde de forme carrée pourvue d'une boudine. Positionnée sur un col de fort diamètre, sa bague spéciale rehaussée d'un cordon se positionne très haut par rapport au buvant et renforce la typicité de ce modèle.

CORPORATE affirme son caractère dynamique et authentique. Elle se distingue par une grande hauteur et une piqûre plus profonde.

Drawing inspiration from the original Bordeaux bottles, **APPARAT** revisits the lines of yesteryear with striking authenticity. With its full silhouette, **APPARAT** stands out with its very small heel diameter and deep, square punt with a "boudine". Positioned on a wide neck, its special cord-wrapped finish is very high and quintessential to this model.

CORPORATE epitomizes energy and authenticity. It stands out due to its great height and deeper punt.

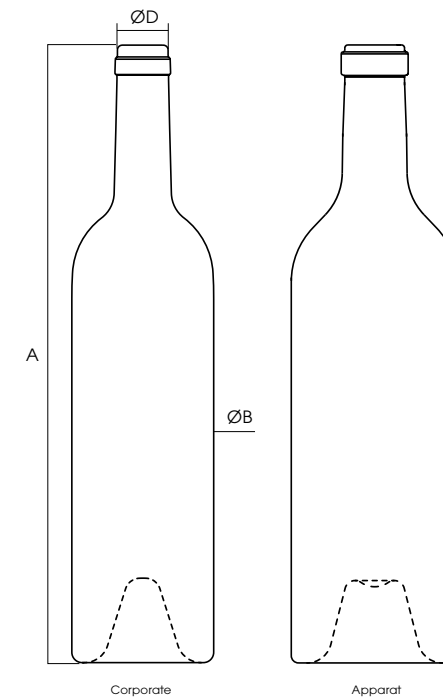



BORDELAISES
**APPARAT &
CORPORATE**
SUPER PREMIUM
ORIGINAL DESIGN



APPARAT



CORPORATE

CONTENANCE CAPACITY	75 cl	75 cl
RÉFÉRENCE REFERENCE	2698 ©	2800
BAGUE FINISH	 Bague Plate SB29 Plate SB29 Finish	 Bague Plate Unique Plate Unique Finish
POIDS WEIGHT (g)	795	700
HAUTEUR TOTALE TOTAL HEIGHT A (mm)	300	329
Ø CORPS BODY Ø B (mm)	81	75.6
Ø DÉBOUCHAGE ENTRANCE BORE D (mm)	18.5	18.5
TEINTE GLASS COLOUR	●	●

● : Antique / Antique Green

© : Modèle déposé "Design Saverglass" / © : Registered "Design Saverglass"

BORDELAISE BELLISSIMA WINE

SUPER PREMIUM

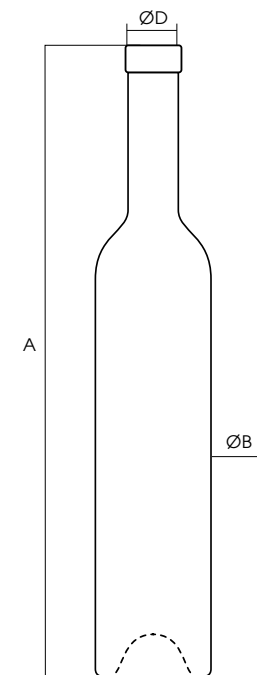

La ligne **BELLISSIMA WINE** attire tous les regards. Elle se démarque par sa silhouette fuselée et originale, gage d'une visibilité exceptionnelle en point de vente. Un caractère généreux qui n'autorise aucun compromis et vient renforcer les valeurs d'excellence d'un contenu de grande qualité.

The **BELLISSIMA WINE** line never fails to turn heads. Distinguished by its tapered, original silhouette, exceptional in-store visibility is guaranteed. A generous character allows no compromise and reinforces the value and excellence of its top-quality contents.



		BELLISSIMA WINE	BELLISSIMA WINE	BELLISSIMA WINE	BELLISSIMA WINE	BELLISSIMA WINE	BELLISSIMA WINE	BELLISSIMA WINE
CONTENANCE CAPACITY		18.7 cl	20 cl	25 cl	37.5 cl	50 cl	75 cl	150 cl
RÉFÉRENCE REFERENCE		3698 © Sur commande To order	3693 © Sur commande To order	3699 © Sur commande To order	1782 ©	1717 ©	1718 ©	2397 ©
BAGUE FINISH								
		Bague plate FA Plate FA Finish	Bague plate FA Plate FA Finish	Bague plate FA Plate FA Finish	Bague plate FA Plate FA Finish	Bague plate FA Plate FA Finish	Bague plate FA Plate FA Finish	Bague plate FA Plate FA Finish
POIDS WEIGHT	(g)	506	470	354	510	665	710	1300
HAUTEUR TOTALE TOTAL HEIGHT	A (mm)	275.5	276.2	275.5	331	352	352	480
Ø CORPS BODY Ø	B (mm)	49.7	49.7	49.7	55.8	62.6	73.8	87
Ø DÉBOUCHAGE ENTRANCE BORE	D (mm)	18.5	18.5	18.5	18.5	18.5	18.5	21.5
TEINTE GLASS COLOUR		● ○	● ○	● ○	● ○	● ○	● ○	● ○

○ : Extra Blanc / Extra White Flint ● : Antique / Antique Green
© : Modèle déposé "Design Saverglass" / © : Registered "Design Saverglass"

BORDELAISE BYBLOS

SUPER PREMIUM



Le modèle **BYBLOS** se distingue par sa silhouette contemporaine et son allure racée. Il affiche une haute stature, une conicité de fût prononcée, un corps parfaitement cylindrique et une épaule discrète. Cette silhouette aux détails design subtils valorisera les vins les plus sélectifs.

BYBLOS is distinctive in its contemporary silhouette and its racy looks. It speaks of high status with its pronounced tapered base, perfectly cylindrical body and discreet shoulder. This silhouette, with its subtle design details, will showcase the most exclusive wines.

BORDELAISE
BYBLOS
SUPER PREMIUM

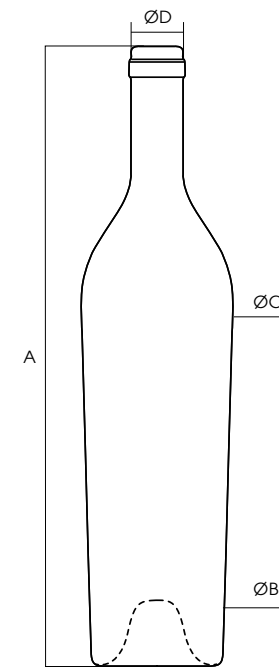

BYBLOS



BYBLOS



BYBLOS BVS

CONTENANCE CAPACITY	75 cl	75 cl	75 cl
RÉFÉRENCE REFERENCE	2792 ©	2792 ©	4051 © Sur commande To order
BAGUE FINISH	 Bague Plate FA Plate FA Finish	 Bague Plate Unique Plate Unique Finish	 Bague BVS 30H60 BVS 30H60 Finish
POIDS WEIGHT (g)	720	720	750
HAUTEUR TOTALE TOTAL HEIGHT A (mm)	328	330	330
Ø PIED BASE Ø B (mm)	69.9	69.9	69.9
Ø ÉPAULE SHOULDER Ø C (mm)	80.5	80.5	80.5
Ø DÉBOUCHAGE ENTRANCE BORE D (mm)	18.5	18.5	20.5
TEINTE GLASS COLOUR	● ○	● ○	● ○

○ : Extra Blanc / Extra White Flint ● : Antique / Antique Green

© : Modèle déposé "Design Saverglass" / © : Registered "Design Saverglass"

BORDELAISE CONSTANCE

SUPER PREMIUM



Dans la lignée des bordelaises, **CONSTANCE** joue la carte du chic intemporel. Marquée par une légère conicité, une épaule charnue et une piqûre profonde, elle dessine les lignes d'un flacon sélect et original.

In the Bordeaux range, **CONSTANCE** plays the timeless chic card. Slightly tapered, with a sloped shoulder and deep punt, it has the lines of an exclusive and original flask.

BORDELAISE
CONSTANCE
SUPER PREMIUM
ORIGINAL DESIGN

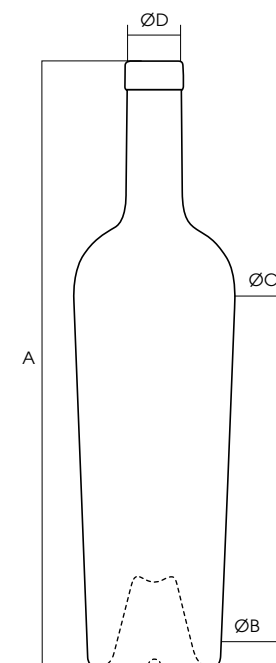

CONSTANCE



CONSTANCE

CONTENANCE
CAPACITY

75 cl

75 cl

RÉFÉRENCE
REFERENCE

5019 ©

5019 ©

BAGUE
FINISH



Bague Plate FA
Plate FA Finish



Bague Carrée Bourgogne Classique
Carrée Bourgogne Classique Finish

POIDS

WEIGHT (g)

860

860

HAUTEUR TOTALE

TOTAL HEIGHT A (mm)

317.6

318

Ø PIED

BASE Ø B (mm)

71.6

71.6

Ø ÉPAULE

SHOULDER Ø C (mm)

86.9

86.9

Ø DÉBOUCHAGE

ENTRANCE BORE D (mm)

18.5

18.5

TEINTE

GLASS COLOUR



● : Antique / Antique Green

© : Modèle déposé "Design Saverglass" / © : Registered "Design Saverglass"

BORDELAISE ICARO

SUPER PREMIUM



BORDELAISE
ICARO
ORIGINAL DESIGN
SUPER PREMIUM

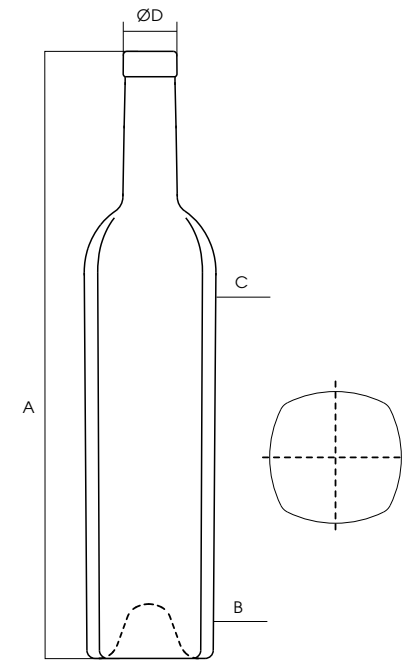

Une bordelaise carrée ? Assurément avant-gardiste, **ICARO** séduira une clientèle en quête de parti-pris stylistique, novateur et affirmé. Iconoclaste, **ICARO** relève avec audace le défi d'une bordelaise tout en conservant l'esprit du modèle originel, soit l'exemple parfait du classique revisité.



A square Bordeaux? Proudly avant-garde, **ICARO** will entice a clientele looking for a stylish, novel and confident statement. The iconoclastic **ICARO** daringly tackles the Bordeaux challenge while retaining the spirit of the original model, as a perfect example of a revisited classic.



ICARO

ICARO

ICARO

CONTENANCE CAPACITY		50 cl	75 cl	150 cl
RÉFÉRENCE REFERENCE		3598 ©	3536 ©	3866 ©
BAGUE FINISH		 Bague Plate FA Plate FA Finish	 Bague Plate FA Plate FA Finish	 Bague Plate FA Plate FA Finish
POIDS WEIGHT	(g)	545	723	1200
HAUTEUR TOTALE TOTAL HEIGHT	A (mm)	300.5	335	397
PIED BASE	B (mm)	60.8 x 60.8	69.7 x 69.7	88.4 x 88.4
ÉPAULE SHOULDER	C (mm)	63.8 x 63.8	72.7 x 72.7	92.2 x 92.2
Ø DÉBOUCHAGE ENTRANCE BORE	D (mm)	18.5	18.5	18.5
TEINTE GLASS COLOUR		●	● ○	● ○ ¹

○ : Extra Blanc / Extra White Flint ● : Antique / Antique Green ¹ : Sur commande / To order

© : Modèle déposé "Design Saverglass" / © : Registered "Design Saverglass"

BORDELAISES PERSONNALISÉES

SUPER PREMIUM



En complément des versions standard « lisses », certains de nos modèles sont proposés dans une version « PERSONNALISABLE » au moyen d'un médaillon gravé à l'épaule. Cette formule raffinée d'écussonnage s'avère extrêmement fidèle au plan du rendu verre de la gravure et particulièrement économique en termes de frais de développement.

In addition to the standard "smooth" versions, some of our models are offered in a "PERSONALIZABLE" version in the form of an engraved locket on the shoulder. This refined approach, capitalizing on the quality of the design, is extremely efficient in terms of glass use and offers very economical development costs.

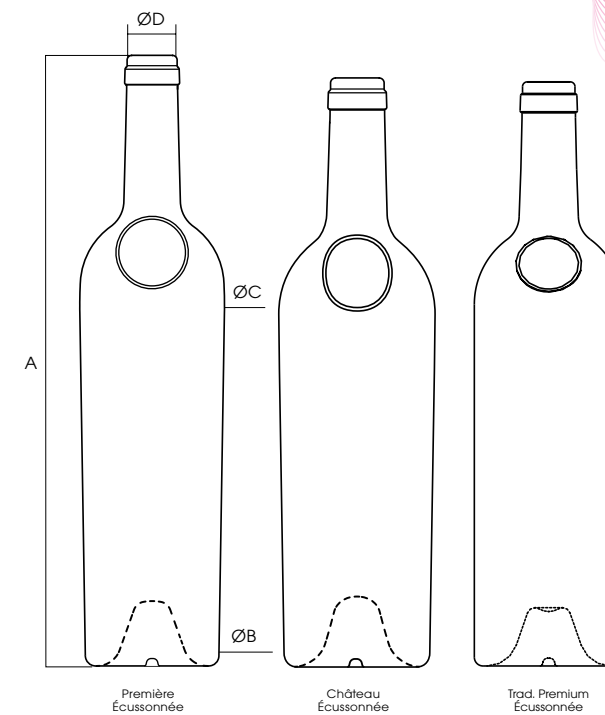

BORDELAISES
PERSONNALISÉES
SUPER PREMIUM
ORIGINAL DESIGN



PREMIÈRE
ÉCUSSONNÉE



CHÂTEAU
ÉCUSSONNÉE



TRAD. PREMIUM
ÉCUSSONNÉE

CONTENANCE CAPACITY		75 cl	75 cl	75 cl
RÉFÉRENCE REFERENCE		2295 Sur commande To order	2039 Sur commande To order	5411 Sur commande To order
BAGUE FINISH		 Bague Plate Unique Plate Unique Finish	 Bague Plate Unique Plate Unique Finish	 Bague Plate Unique Plate Unique Finish
POIDS WEIGHT	(g)	715	605	565
HAUTEUR TOTALE TOTAL HEIGHT	A (mm)	329.5	303	300.5
Ø PIED BASE Ø	B (mm)	72.1	74.4	76.6
Ø ÉPAULE SHOULDER Ø	C (mm)	78.1	79.4	76.6
Ø DÉBOUCHAGE ENTRANCE BORE	D (mm)	18.5	18.5	18.5
TEINTE GLASS COLOUR		●	●	●

● : Antique / Antique Green

BORDELAISE SAINT-PIERRE

SUPER PREMIUM



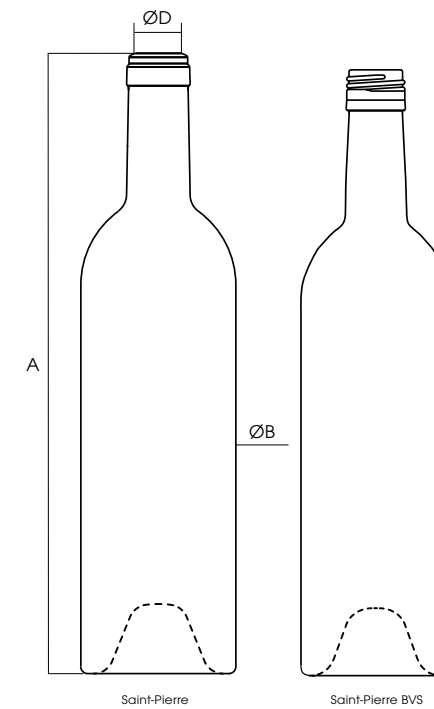

Travaillé sur la base d'un poids de verre généreux, le design de la Bordelaise **SAINT-PIERRE** se singularise par un fût cylindrique, un rayon de jable nerveux et un col court de fort diamètre, surmonté d'une imposante bague carrée bourgogne. À travers ses lignes pures et fluides, le modèle **SAINT-PIERRE** exprime une grande élégance intemporelle, matinée de modernité.

With its generous glass weight, the design of the Bordelaise **SAINT-PIERRE** stands out with its cylindrical base, a racy heel diameter and short wide neck, on which rests an imposing square Bordeaux finish. Its pure, flowing lines give **SAINT-PIERRE** a grand, timeless elegance, with a touch of modernity.



BORDELAISE
SAINT-PIERRE
SUPER PREMIUM
ORIGINAL DESIGN

CONTENANCE CAPACITY		75 cl	75 cl	150 cl
RÉFÉRENCE REFERENCE		T298 ©	3832 © Sur commande To order	3783 ©
BAGUE FINISH		 Bague Carrée Bourgogne SB30 Carrée Bourgogne SB30 Finish	 Bague BVS 31.5H60 BVS 31.5H60 Finish	 Bague Carrée Bourgogne SB30 Carrée Bourgogne SB30 Finish
POIDS WEIGHT	(g)	785	780	1115
HAUTEUR TOTALE TOTAL HEIGHT	A (mm)	312	312	380
Ø CORPS BODY Ø	B (mm)	78	78,9	95
Ø DÉBOUCHAGE ENTRANCE BORE	D (mm)	18,5	20,5	18,5
TEINTE GLASS COLOUR		●	●	●

● : Antique / Antique Green

© : Modèle déposé "Design Saverglass" / © : Registered "Design Saverglass"

BORDELAISES CONIQUES

PREMIUM
ORIGINAL
DESIGN

ALIÉNOR 2 propose une déclinaison épurée de la Bordelaise ALIÉNOR tout en conservant le tempérament de son design originel.

Avec son design racé hérité des formes bordelaises classiques, le modèle **ICON** est une référence pour magnifier les grands vins.

ALIÉNOR 2 offers a refined version of the Bordelaise ALIÉNOR while retaining the temperament of its original design.

With its racy design drawing on classic Bordeaux shapes, the **ICON** model is, as its name suggests, "iconic" thus enhancing great wines.

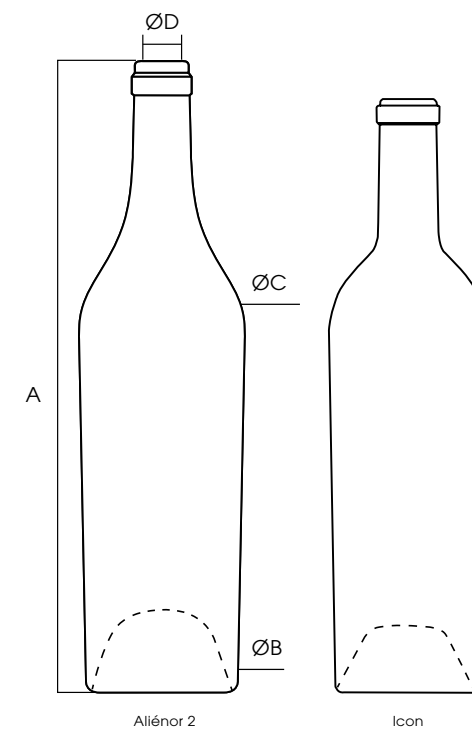

Aliénor 2

Icon



ALIÉNOR 2



ICON



ICON

CONTENANCE CAPACITY

75 cl

75 cl

150 cl

RÉFÉRENCE REFERENCE

2643 ©

4387 ©

5163 ©

BAGUE FINISH



Bague Plate Unique
Plate Unique Finish



Bague Plate SB29.5
Plate SB29.5 Finish



Bague Plate SB29.5
Plate SB29.5 Finish

POIDS WEIGHT

(g)

700

760

1218

HAUTEUR TOTALE TOTAL HEIGHT

A (mm)

313.6

308

376.1

Ø PIED BASE Ø

B (mm)

74.7

75.8

94.2

Ø ÉPAULE SHOULDER Ø

C (mm)

80.8

82

101.9

Ø DÉBOUCHAGE ENTRANCE BORE

D (mm)

18.5

18.5

18.5

TEINTE GLASS COLOUR

● ○¹

● ○

● ○

○ : Extra Blanc / Extra White Flint ● : Antique / Antique Green ¹ : Sur commande / To order

© : Modèle déposé "Design Saverglass" / © : Registered "Design Saverglass"

BORDELAISE SIGNATURE

PREMIUM
ORIGINAL
DESIGN



Renouvelant le design plutôt classique des bouteilles destinées notamment aux vins du soleil et aux vins de cépage, le modèle **SIGNATURE** propose un contenant résolument innovant. Son col long et son fût conique prolongé par un talon affirment un positionnement moderne et audacieux.

Updating the more classic design of bottles, and intended mainly for sunny wines and varietal wines, **SIGNATURE** offers a defiantly innovative container. Its long neck and tapered base with an extended heel give it a modern, daring look.

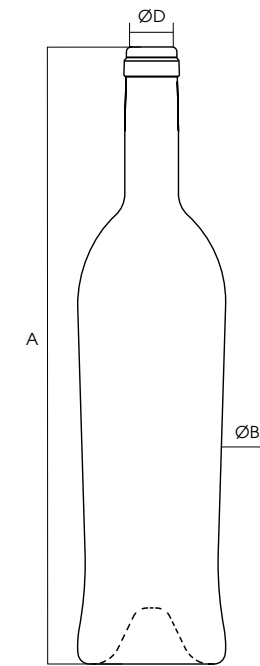

BORDELAISE
SIGNATURE
PREMIUM
ORIGINAL
DESIGN



		50 cl	75 cl	150 cl
CONTENANCE CAPACITY		50 cl	75 cl	150 cl
RÉFÉRENCE REFERENCE		2672 ©	2284 ©	2671 ©
BAGUE FINISH		 Bague Plate Unique Plate Unique Finish	 Bague Plate Unique Plate Unique Finish	 Bague Carrée Spéciale Special Carrée Finish
POIDS WEIGHT	(g)	500	700	1155
HAUTEUR TOTALE TOTAL HEIGHT	A (mm)	289	330	406.5
Ø CORPS BODY Ø	B (mm)	69.3	79.2	98.7
Ø DÉBOUCHAGE ENTRANCE BORE	D (mm)	18.5	18.5	18.5
TEINTE GLASS COLOUR		● ○ ¹	● ○	● ○ ¹

○ : Extra Blanc / Extra White Flint ● : Antique / Antique Green ¹ : Sur commande / To order

© : Modèle déposé "Design Saverglass" / © : Registered "Design Saverglass"

BORDELAISE ANCIENNE

PREMIUM
PREMIUM
DESIGN



De facture classique à l'élégance racée, la Bordelaise **ANCIENNE** décline avec style une forme conique, un très bel arrondi de l'épaule et une parfaite justesse dans les proportions.

Classically crafted with racy elegance, the Bordelaise **ANCIENNE** offers a stylish tapered shape, beautifully rounded shoulder, and perfect proportions.

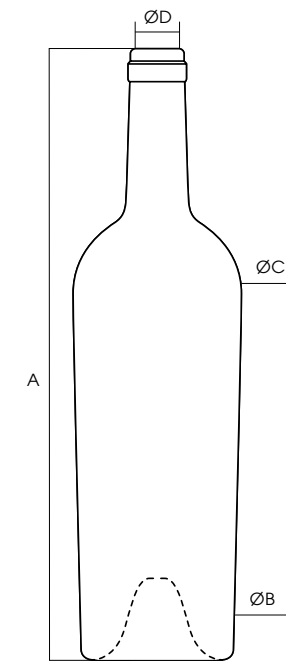



BORDELAISE
ANCIENNE
PREMIUM
DESIGN



ANCIENNE

MAGNUM ANCIENNE

CONTENANCE CAPACITY		75 cl	150 cl
RÉFÉRENCE REFERENCE		1189 © Sur commande To order	T233 ©
BAGUE FINISH		 Baguette Plate Unique Plate Unique Finish	 Baguette Plate Unique Plate Unique Finish
POIDS WEIGHT	(g)	650	920
HAUTEUR TOTALE TOTAL HEIGHT	A (mm)	299	359
Ø PIED BASE Ø	B (mm)	74.8	91.3
Ø ÉPAULE SHOULDER Ø	C (mm)	82.8	101
Ø DÉBOUCHAGE ENTRANCE BORE	D (mm)	18.5	18.5
TEINTE GLASS COLOUR		● ○ ●	●

○ : Extra Blanc / Extra White Flint ● : Antique / Antique Green ● : Champagne / Champagne Green

© : Modèle déposé "Design Saverglass" / © : Registered "Design Saverglass"

BORDELAISE CAPRI

PREMIUM
PREMIUM
DESIGN

Longiligne, gracieuse et particulièrement fonctionnelle, la Bordelaise **CAPRI** esquisse une silhouette d'une pureté très actuelle. Son corps cylindrique et son épaulement arrondi s'expriment tout en légèreté (poids de verre de 600 g) pour obtenir un flacon à l'esthétique distinctive.

Sleek, graceful and particularly functional, the Bordelaise **CAPRI** shows a purity of shape that is very much today. Its cylindrical body and rounded shoulder speak of elegance (glass weight 600g) for an aesthetically distinctive bottle.

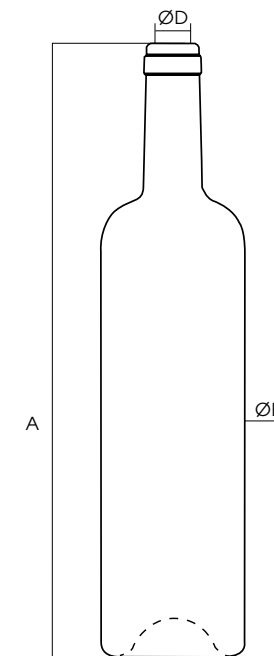

CAPRI

CONTENANCE
CAPACITY

75 cl

RÉFÉRENCE
REFERENCE

4616 ©

BAGUE
FINISH



Bague Plate Unique
Plate Unique Finish

POIDS
WEIGHT

(g)

600

HAUTEUR TOTALE
TOTAL HEIGHT

A (mm)

315

Ø CORPS
BODY Ø

B (mm)

73.7

Ø DÉBOUCHAGE
ENTRANCE BORE

D (mm)

18.5

TEINTE
GLASS COLOUR

● ○¹

○ : Extra Blanc / Extra White Flint ● : Antique / Antique Green ¹ : Sur commande / To order

© : Modèle déposé "Design Saverglass" / © : Registered "Design Saverglass"

BORDELAISE
CAPRI
PREMIUM
PREMIUM
DESIGN

BORDELAISE CAUDALIE

PREMIUM



La Bordelaise **CAUDALIE** propose une version stylisée et rajeunie du modèle APPARAT. Ce classique de grand standing se renouvelle et s'allège grâce notamment à un diamètre corps réduit, une épaule singulière et un col doté d'une bague carrée. Autre apport de l'allègement : son positionnement tarifaire attractif.

The Bordelaise **CAUDALIE** offers a stylish more youthful version of APPARAT. This legendary classic has been modernized and slimmed with a narrower body, a distinctive shoulder and a neck with a square finish. Another slimline feature is its attractive price point.



Caudalie

Caudalie BVS



CAUDALIE

CAUDALIE BVS

CONTENANCE
CAPACITY

75 cl

75 cl

RÉFÉRENCE
REFERENCE

3349 ©

4518 ©
Sur commande
To order

BAGUE
FINISH



Bague Plate Wine
Plate Wine Finish



Bague BVS 31.5H60
BVS 31.5H60 Finish

POIDS

WEIGHT (g)

600

600

HAUTEUR TOTALE

TOTAL HEIGHT A (mm)

300

300

Ø CORPS

BODY Ø B (mm)

77.5

77.4

Ø DÉBOUCHAGE

ENTRANCE BORE D (mm)

18.5

20

TEINTE

GLASS COLOUR

● ○

●

○ : Extra Blanc / Extra White Flint ● : Antique / Antique Green

© : Modèle déposé "Design Saverglass" / © : Registered "Design Saverglass"

BORDELAISE
CAUDALIE
PREMIUM
PREMIUM
DESIGN

BORDELAISE EDEN

PREMIUM



La Bordelaise **EDEN** innove et surprend. Sa compacité dimensionnelle comparée à l'impression de volume qu'elle transmet la conforte sur un positionnement véritablement distinctif. Affichant un poids de verre de 600 g seulement, le modèle **EDEN** se singularise également par son profil de col surmonté d'une très belle bague carrée. La Bordelaise **EDEN** se rattache à une gamme composée de la Bordelaise PARADIS (840 g) et de la Bordelaise ALEKA (1200 g) qui offrent toutes deux une silhouette conique et un dessin d'épaule caractéristiques.

The Bordelaise **EDEN** is innovative and surprising. Its compact size, compared to the impression it gives of volume, testifies to its comfortable positioning as a truly distinctive bottle. With a glass weight of only 600g, **EDEN** stands out due to the profile of its neck topped by a very beautiful square finish. The Bordelaise **EDEN** is part of a range that includes the Paradis (840g) and Aleka (1200g), each of which offers a tapered silhouette and characteristic designer shoulder.

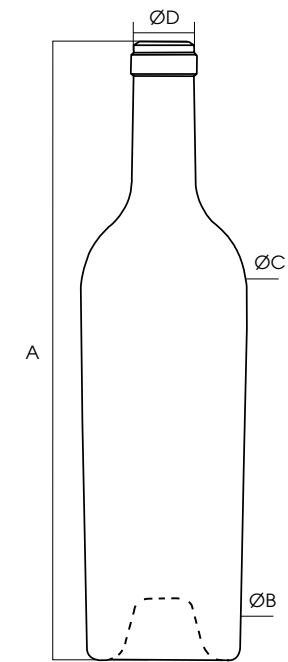

BORDELAISE
EDEN
PREMIUM



EDEN

CONTENANCE
CAPACITY

75 cl

RÉFÉRENCE
REFERENCE

4383 ©

BAGUE
FINISH



Bague Carrée Bourgogne
Carrée Bourgogne Finish

POIDS
WEIGHT

(g)

600

HAUTEUR TOTALE
TOTAL HEIGHT

A (mm)

300

Ø PIED
BASE Ø

B (mm)

74

Ø ÉPAULE
SHOULDER Ø

C (mm)

81

Ø DÉBOUCHAGE
ENTRANCE BORE

D (mm)

18.5

TEINTE
GLASS COLOUR

● ○¹

○ : Extra Blanc / Extra White Flint ● : Antique / Antique Green ¹ : Sur commande / To order

© : Modèle déposé "Design Saverglass" / © : Registered "Design Saverglass"

BORDELAISE MAESTRIA

PREMIUM



BORDELAISE
MAESTRIA
PREMIUM
PREMIUM DESIGN



Rayon d'épaulement arrondi, fût conique, piqure prononcée de 35 mm, hauteur traditionnelle de 313 mm... Si les bordelaises anciennes se distinguent à travers des détails très identifiables, **MAESTRIA** s'impose elle comme le modèle le plus compétitif de cette série affichant un poids plume de 590 g seulement.

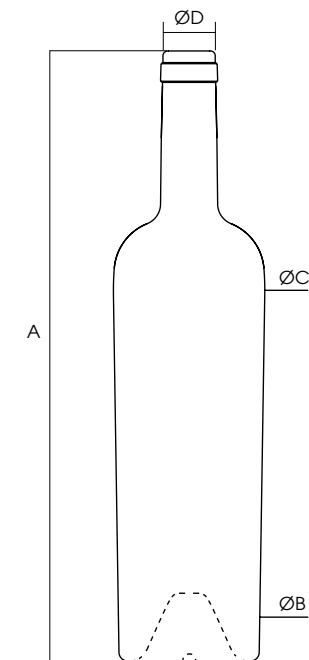

Rounded shoulder, tapered base, pronounced 35mm punt, traditional 313mm height... If the Bordelaises of old had distinctive, very identifiable details, **MAESTRIA** stands out as the most competitive model of this series with a glass weight of just 590g.



MAESTRIA



MAESTRIA

CONTENANCE CAPACITY		75 cl	75 cl
RÉFÉRENCE REFERENCE		5200 ©	5200 ©
BAGUE FINISH		 Bague Plate Unique Plate Unique Finish	 Bague Plate FA Plate FA Finish
POIDS WEIGHT	(g)	590	590
HAUTEUR TOTALE TOTAL HEIGHT	A (mm)	315	313
Ø PIED BASE Ø	B (mm)	72.4	72.4
Ø ÉPAULE SHOULDER Ø	C (mm)	78.2	78.2
Ø DÉBOUCHAGE ENTRANCE BORE	D (mm)	18.5	18.5
TEINTE GLASS COLOUR		● ○	● ○

○ : Extra Blanc / Extra White Flint ● : Antique / Antique Green

© : Modèle déposé "Design Saverglass" / © : Registered "Design Saverglass"

LES PORTO

PREMIUM

PREMIUM
DESIGN



VINTAGE DOURO a été spécifiquement pensée pour le conditionnement des vins de Porto les plus prestigieux. Imaginé dans le plus pur respect des lignes traditionnelles des bouteilles type Porto, ce modèle s'applique à parfaire certains détails, tant esthétiques que fonctionnels. Son épaule très arrondie souligne la forme galbée du mollet bas-col destiné à recueillir le dépôt du vin lors de la phase de vieillissement. Un sommet de col cylindrique surmonté d'une bague iloise ou d'une bague plate garantit par ailleurs une parfaite étanchéité.

VINTAGE PORTO doit son nom au célèbre vin millésimé qui a vieilli au moins dix ans. De forme traditionnelle, cette bouteille se veut généreuse tant au niveau de son poids de verre que de ses proportions. Authentique et rassurante, **VINTAGE PORTO** signe ainsi l'origine et la noblesse des grands vins mutés du monde entier.

VINTAGE DOURO is specially designed to showcase the most prestigious Port wines. Created with utmost respect for the traditional lines of Port bottles, this model sets out to perfect aesthetic and functional details. Its very rounded shoulder emphasizes the sloped shape of the calf at the lower neck, designed to collect wine sediment during the aging stage. A cylindrical upper neck topped by a flat double collar Iloise finish or flat finish ensures a perfect seal.

VINTAGE PORTO owes its name to the famous vintage wine that is aged for at least 10 years. With its traditional shape, this bottle is generous in both glass weight and proportions. Authentic and reassuring, **VINTAGE PORTO** testifies to the origin and nobility of the world's great still wines.

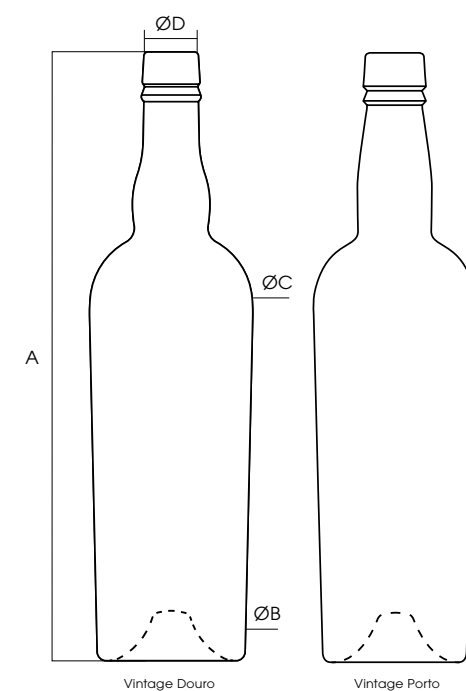



VINTAGE DOURO



VINTAGE DOURO



VINTAGE PORTO

CONTENANCE CAPACITY		75 cl	75 cl	75 cl
RÉFÉRENCE REFERENCE		2703 ©	2703 ©	0011 ©
BAGUE FINISH		 Bague Plate FA Plate FA Finish	 Bague Iloise 2 Iloise 2 Finish	 Bague Iloise Porto Iloise Porto Finish
POIDS WEIGHT	(g)	660	665	700
HAUTEUR TOTALE TOTAL HEIGHT	A (mm)	296	306.5	306.5
Ø PIED BASE Ø	B (mm)	74.5	74.5	74.5
Ø ÉPAULE SHOULDER Ø	C (mm)	82.2	82.2	82.2
Ø DÉBOUCHAGE ENTRANCE BORE	D (mm)	18.5	17	18.5
TEINTE GLASS COLOUR		●	● ●	● ● ¹

● : Antique / Antique Green ● : Jaune Foncé / Dark Amber ¹ : Sur commande / To order

© : Modèle déposé "Design Saverglass" / © : Registered "Design Saverglass"

LES PORTO

PREMIUM
DESIGN

BORDELAISE RIVIERA

PREMIUM



BORDELAISE
RIVIERA
PREMIUM
PREMIUM DESIGN



Déployant des proportions idéalement équilibrées, la Bordelaise **RIVIERA** séduira les amateurs de grandes contenances grâce à l'élégance de sa silhouette, son épaulement et son col généreux. Le design épuré du magnum **RIVIERA** mettra en scène de manière spectaculaire aussi bien les vins rosés grâce au verre Extra Blanc, que les vins rouges et vins blancs en choisissant la teinte Antique.

With ideally balanced proportions, the Bordelaise **RIVIERA** will seduce lovers of grand containers by the elegance of its silhouette, its shoulder and its generous neck. The pure design of the **RIVIERA** magnum spectacularly showcases rosé wines in Extra White glass, as well as red and white wines in the Antique Green tint.

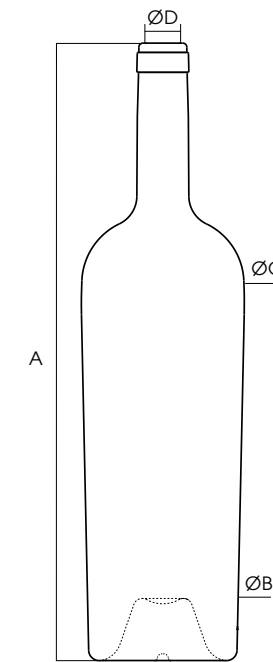

RIVIERA

CONTENANCE CAPACITY	150 cl
-------------------------------	--------

RÉFÉRENCE REFERENCE	5183
-------------------------------	------

BAGUE FINISH	 Carrée Spéciale Special Carrée
------------------------	--

POIDS WEIGHT	(g)	979
------------------------	-----	-----

HAUTEUR TOTALE TOTAL HEIGHT	A (mm)	380
---------------------------------------	--------	-----

Ø PIED BASE Ø	B (mm)	91.3
-------------------------	--------	------

Ø ÉPAULE SHOULDER Ø	C (mm)	100.3
-------------------------------	--------	-------

Ø DÉBOUCHAGE ENTRANCE BORE	D (mm)	18.5
--------------------------------------	--------	------

TEINTE GLASS COLOUR	● ○
-------------------------------	-----

○ : Extra Blanc / Extra White Flint ● : Antique / Antique Green

BORDELAISE ANCIENNE 2

STANDARD PREMIUM

PREMIUM DESIGN



Dans la lignée de la Bordelaise ANCIENNE, le modèle **ANCIENNE 2** décline une version plus accessible. Reprenant les caractéristiques esthétiques qui ont fait le succès de la gamme ANCIENNE, elle conserve sa rondeur d'épaule et une élégante conicité.

In the Bordelaise ANCIENNE line, the **ANCIENNE 2** is a more affordable version. With the aesthetic features that made the ANCIENNE range such a success, it retains its round shoulder and tapered elegance.

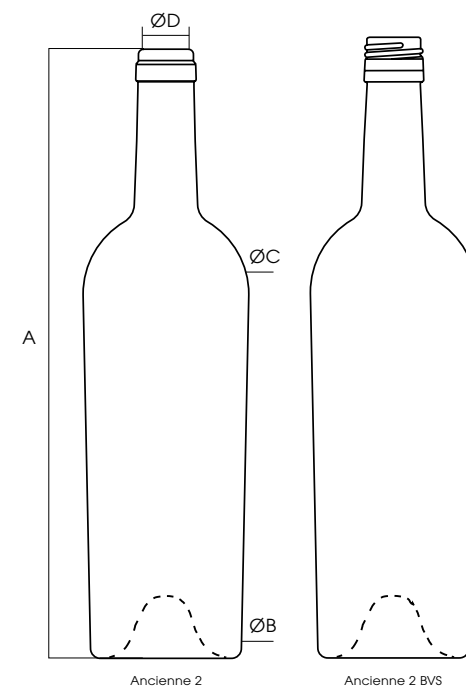

BORDELAISE ANCIENNE 2
STANDARD PREMIUM

PREMIUM DESIGN



ANCIENNE 2



ANCIENNE 2 BVS

CONTENANCE
CAPACITY

75 cl

75 cl

RÉFÉRENCE
REFERENCE

2784

3407

BAGUE
FINISH



Bague Plate Unique
Plate Unique Finish



Bague BVS 30H60
BVS 30H60 Finish

POIDS
WEIGHT

(g)

600

615

HAUTEUR TOTALE
TOTAL HEIGHT

A (mm)

299

299

Ø PIED
BASE Ø

B (mm)

74.1

74.1

Ø ÉPAULE
SHOULDER Ø

C (mm)

81.4

81.4

Ø DÉBOUCHAGE
ENTRANCE BORE

D (mm)

18.5

20

TEINTE
GLASS COLOUR

● ○

● ○¹

○ : Extra Blanc / Extra White Flint

● : Antique / Antique Green

¹ : Sur commande / To order

BORDELAISE SANTIAGO

STANDARD PREMIUM



SANTIAGO réveille la silhouette bordelaise en proposant une interprétation plus accessible des modèles traditionnels. Son élégance s'exprime au travers d'un corps cylindrique élancé - sa hauteur est de 325 mm - une épaule arrondie, un col fuselé surmonté d'une bague plate unique, pour un poids de 560 g.

SANTIAGO enlivens the Bordelaise silhouette by offering a more affordable interpretation of the traditional models. Its elegance is evident in its sleek cylindrical body - 325mm high - a rounded shoulder, tapered neck topped by a unique flat finish, and all weighing just 560g.

BORDELAISE
SANTIAGO
STANDARD PREMIUM

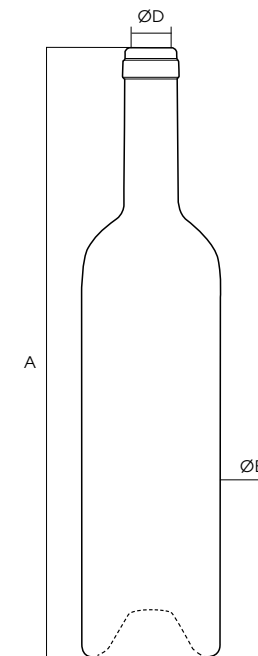

SANTIAGO

CONTENANCE
CAPACITY

75 cl

RÉFÉRENCE
REFERENCE

4565

BAGUE
FINISH



Bague Plate Unique
Plate Unique Finish

POIDS
WEIGHT

(g)

560

HAUTEUR TOTALE
TOTAL HEIGHT

A (mm)

325

Ø CORPS
BODY Ø

B (mm)

74.2

Ø DÉBOUCHAGE
ENTRANCE BORE

D (mm)

18.5

TEINTE
GLASS COLOUR

● ○¹

○ : Extra Blanc / Extra White Flint

● : Antique / Antique Green

¹ : Sur commande / To order

BORDELAISE BAMBOO WINE

STANDARD PREMIUM



Héritière de la ligne BELLISIMA, **BAMBOO WINE** révèle toute sa modernité à travers une esthétique pure et une silhouette spectaculaire. Un trait précis, un style exigeant et très contemporain caractérisent cette bouteille.

A descendant of the BELLISIMA line, **BAMBOO WINE** speaks of modernity with its pure aesthetic and spectacular silhouette. Precise lines and a very exacting and contemporary style characterize this bottle.

BORDELAISE
BAMBOO WINE
STANDARD PREMIUM

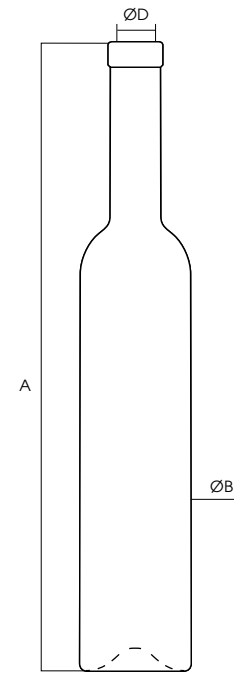

BAMBOO WINE



BAMBOO WINE

CONTENANCE
CAPACITY

50 cl

75 cl

RÉFÉRENCE
REFERENCE

2424

2425

BAGUE
FINISH



Bague Plate FA
Plate FA Finish



Bague Plate Bouchon à tête
Plate Bouchon à tête Finish

POIDS

WEIGHT (g)

660

620

HAUTEUR TOTALE

TOTAL HEIGHT A (mm)

352

341.5

Ø CORPS

BODY Ø B (mm)

62

72.6

Ø DÉBOUCHAGE

ENTRANCE BORE D (mm)

18.5

18.5

TEINTE

GLASS COLOUR

● ○

● ○

○: Extra Blanc / Extra White Flint ●: Antique / Antique Green

BORDELAISES CAPRICE & CHATEAU

STANDARD PREMIUM



CAPRICE réinterprète les contours de la silhouette bordelaise en y insufflant une touche de modernité. Elle conserve ainsi un corps cylindrique élancé et une épaule tout en rondeur. L'originalité ainsi que le renouvellement de la ligne s'expriment à travers un large choix de bagues qui viennent personnaliser son long col.

La bouteille **CHÂTEAU** constitue une première évolution de la Bordelaise TRADITION. Une légère conicité, une piqûre accentuée, et une hauteur conforme au modèle de référence forment les principaux atouts de ce modèle.

CAPRICE reinterprets the lines of the classic Bordeaux silhouette by adding a touch of modernity. It retains a sleek cylindrical body and very round shoulder. Original and new are both featured in its large choice of finishes to customize its long neck.

CHÂTEAU is the first evolution of the Bordelaise TRADITION. Its slightly tapered shape, accentuated punt, and classic height are the main features of this model.

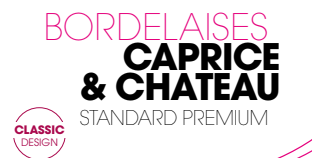
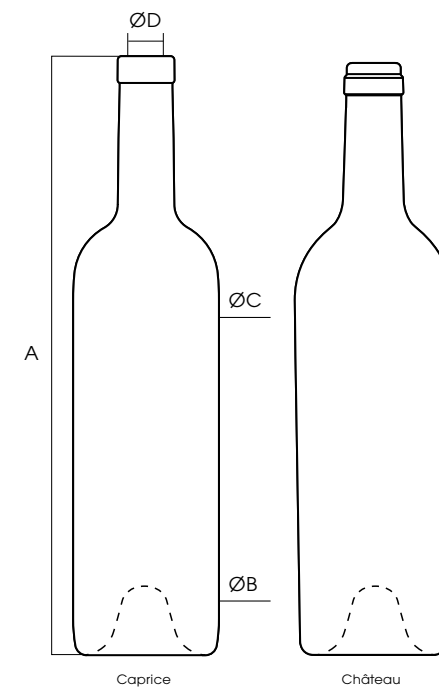

CONTENANCE CAPACITY		75 cl	75 cl	75 cl
RÉFÉRENCE REFERENCE		1731	1731	2040
BAGUE FINISH		 Bague Plate FA Plate FA Finish	 Bague Plate Unique Plate Unique Finish	 Bague Plate Unique Plate Unique Finish
POIDS WEIGHT	(g)	620	620	605
HAUTEUR TOTALE TOTAL HEIGHT	A (mm)	313	315	303
Ø PIED BASE Ø	B (mm)	76.2	76.2	74.4
Ø ÉPAULE SHOULDER Ø	C (mm)	76.2	76.2	79.4
Ø DÉBOUCHAGE ENTRANCE BORE	D (mm)	18.5	18.5	18.5
TEINTE GLASS COLOUR		●	●	● ○ ¹ ● ¹

○ : Extra Blanc / Extra White Flint ● : Antique / Antique Green ● : Champagne / Champagne Green ¹ : Sur commande / To order

CLASSIC BORDELAISE

STANDARD PREMIUM



Le modèle **CLASSIC BORDELAISE** ravive ingénieusement la silhouette générique de la bordelaise, tout en préservant ses grandes qualités de praticité. Une ligne haute et fine, des dimensions généreuses, un épaulement de facture classique confèrent à cette gamme un caractère dynamique et authentique.

The **CLASSIC BORDELAISE** ingeniously enlivens the generic Bordeaux silhouette while preserving its great practicality. Tall, sleek outline, generous dimensions, and a classically crafted shoulder give this range a dynamic and authentic character.

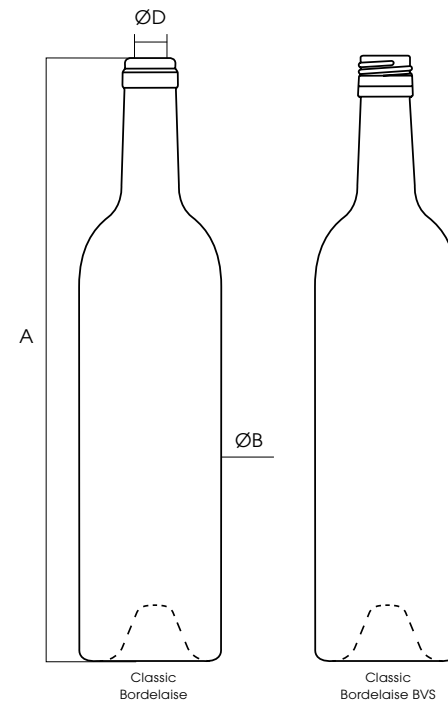

CONTENANCE CAPACITY		37.5 cl	37.5 cl	50 cl	50 cl	75 cl	75 cl	37.5 cl	75 cl
RÉFÉRENCE REFERENCE		3887	3887	3599	3599	3493	3493	3451	2987
BAGUE FINISH		Bague Plate Unique Plate Unique Finish	Bague Plate FA Plate FA Finish	Bague Plate FA Plate FA Finish	Bague Plate Unique Plate Unique Finish	Bague Plate Unique Plate Unique Finish	Bague Plate FA Plate FA Finish	Bague BVS 30H60 BVS 30H60 Finish	Bague BVS 30H60 BVS 30H60 Finish
POIDS WEIGHT	(g)	400	400	500	500	700	695	380	707
HAUTEUR TOTALE TOTAL HEIGHT	A (mm)	260	258	298.5	300.5	321.3	319.3	259	321.3
Ø CORPS BODY Ø	B (mm)	61.3	61.3	64.9	64.9	75.6	75.6	61	75.6
Ø DÉBOUCHAGE ENTRANCE BORE	D (mm)	18.5	18.5	18.5	18.5	18.5	18.5	20	20
TEINTE GLASS COLOUR		● ○	● ¹ ○	● ○	● ○	● ○	● ○	● ○	● ○

○ : Extra Blanc / Extra White Flint ● : Antique / Antique Green ¹ : Sur commande / To order



CLASSIC BORDELAISE

STANDARD PREMIUM



BORDELAISES PREMIÈRE & AVANT-PREMIÈRE

STANDARD PREMIUM CLASSIC DESIGN



PREMIÈRE s'inspire directement du profil de la bordelaise pour mieux s'en affranchir. Caractérisée par un trait vif et agile, sa silhouette légèrement conique exprime une modernité certaine. Le modèle bénéficie d'une gamme très large proposant un grand choix de contenances et une vaste palette de teintes et de bagues.

PREMIÈRE is directly inspired by the Bordelaise profile to make the best impression. Characterized by a lively agile outline, its slightly tapered silhouette expresses a certain modernity. The model offers the benefit of a very wide choice of containers and an extensive pallet of colors and finishes.

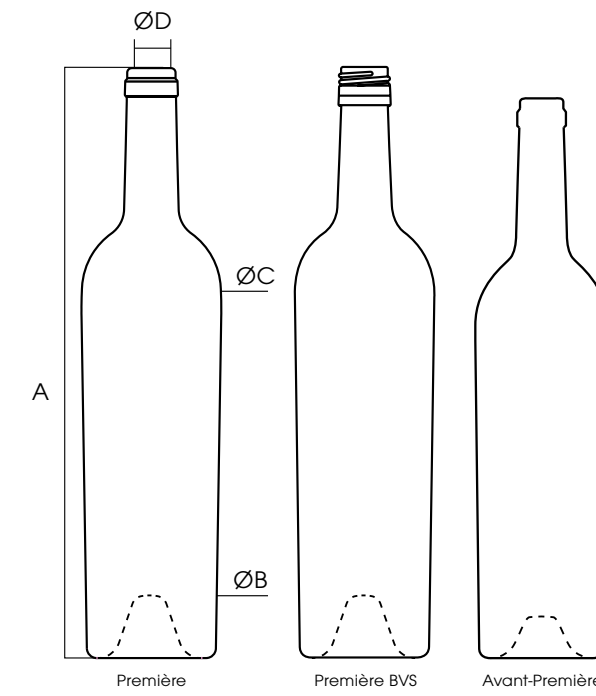

	PREMIÈRE	PREMIÈRE	PREMIÈRE	PREMIÈRE	PREMIÈRE BVS	PREMIÈRE	PREMIÈRE	AVANT-PREMIÈRE
CONTENANCE CAPACITY	37.5 cl	50 cl	75 cl	75 cl	75 cl	150 cl	300 cl	75 cl
RÉFÉRENCE REFERENCE	1806	2171	1735	1735	3221	1805	3222	2130
BAGUE FINISH	Bague Plate Unique Plate Unique Finish	Bague Plate Unique Plate Unique Finish	Bague Plate Unique Plate Unique Finish	Bague Plate FA Plate FA Finish	Bague BVS 30H60 BVS 30H60 Finish	Bague Carrée Spéciale Special Carrée Finish	Bague Plate Unique Plate Unique Finish	Bague Plate Unique Plate Unique Finish
POIDS WEIGHT (g)	410	500	715	715	715	1155	1710	600
HAUTEUR TOTALE TOTAL HEIGHT A (mm)	272.5	289.3	329.5	327.5	329.5	399	478	325
Ø PIED BASE Ø B (mm)	56.6	63	72.1	72.1	71.9	89.5	112.1	73.5
Ø ÉPAULE SHOULDER Ø C (mm)	62.1	68.2	78.1	78.1	77.9	97.5	121.1	76.5
Ø DÉBOUCHAGE ENTRANCE BORE D (mm)	18.5	18.5	18.5	18.5	20	18.5	24	18.5
TEINTE GLASS COLOUR	● ○	● ○	● ○	● ○	● ○ ¹	● ○	● ○	● ○

○ : Extra Blanc / Extra White Flint ● : Antique / Antique Green ¹ : Sur commande / To order



BORDELAISES PREMIERE & AVANT-PREMIERE

STANDARD PREMIUM



BORDELAISES TRADITION

STANDARD PREMIUM



La Bordelaise **TRAD. PREMIUM** délivre une interprétation contemporaine de la Bordelaise **TRADITION**. Préservant les caractéristiques dimensionnelles du modèle originel, ce flacon se distingue notamment par une piqure parée d'une boudine et par un rayon de jable nerveux très actuel.

The Bordelaise **TRAD. PREMIUM** delivers a contemporary interpretation of the Bordelaise **TRADITION**. With the same dimensional characteristics as the original, this bottle stands out mainly by its punt with a "boudine" and a very modern racy heel diameter.

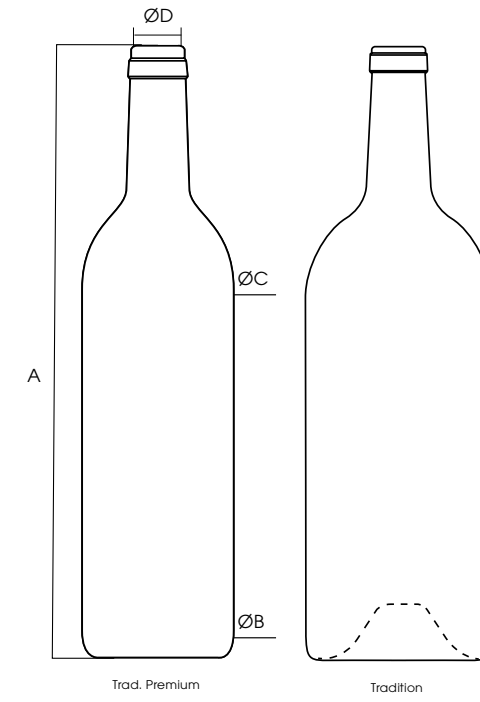

CONTENANCE CAPACITY (cl)	37.5 cl	75 cl	75 cl	150 cl	150 cl	150 cl	300 cl	500 cl	600 cl
RÉFÉRENCE REFERENCE	4558	4427	4559	0099	4655	4692 Sur commande To order	1434	0711	0714
BAGUE FINISH									
POIDS WEIGHT (g)	300	550	566	1050	1040	1057	1630	2985	3120
HAUTEUR TOTALE TOTAL HEIGHT A (mm)	237.5	300.5	300.5	357	356	357	417.5	466	492.8
Ø PIED BASE Ø B (mm)	61.6	76.6	76.6	99.2	99	99.4	127.3	152.7	156.5
Ø ÉPAULE SHOULDER Ø C (mm)	61.6	76.6	76.6	99.2	99	99.4	127.3	157	164.5
Ø DÉBOUCHAGE ENTRANCE BORE D (mm)	18.5	18.5	19	18.5	18.5	19	24	31.5	31.5
TEINTE GLASS COLOUR	● ○	● ○	● ○	● ○	● ○	●	● ○ ¹ ●	●	●

○ : Extra Blanc / Extra White Flint ● : Antique / Antique Green ● : Champagne / Champagne Green ¹ : Sur commande / To order



BORDELAISES TRADITION

STANDARD PREMIUM

CLASSIC
DESIGN

RÉALISATIONS BORDELAISES BORDELAISES PROJECTS



GRAND
APPARAT

1855

PARADIS

CONSTANCE
SUPERBIA

MAESTRIA

CAUDALIE

SANTIAGO

ICON

CLASSIC
BORDELAISE
BYBLOS

BOURGOGNES

ORIGINAL DESIGN

BOURGOGNE 1859	82
BOURGOGNES IMPÉRIALES	84
BOURGOGNE BOURGEOISE	86
BOURGOGNE CÉLESTE	88
BOURGOGNE MAXIMA	90
BOURGOGNE SABINE	92
BOURGOGNES TENDANCE	94
BOURGOGNES PERSONNALISÉES	96
BOURGOGNES CHARDONNAY & ATLAS	98

PREMIUM DESIGN

BOURGOGNE GRAVILLE	100
BOURGOGNE JUSTINE	102
BOURGOGNE TASTEVINE	104
BOURGOGNE VIN GRAND CRU	106

CLASSIC DESIGN

BOURGOGNES CÉPAGE & AGAPE	108
BOURGOGNE ÉLÉGANCE	110
BOURGOGNE GRAND MILLÉSIME	112
BOURGOGNES PRESTIGE	114
BOURGOGNES TRADITION	116

BOURGOGNE 1859

EXTRA PREMIUM



Authentique « bouteille d'époque », la Bourgogne 1859 reproduit la forme originelle de la bouteille bourguignonne. Mêmes proportions généreuses, mêmes épaules légèrement asymétriques, même type de bague, et surtout même profil de piqûre très profonde au plan de pose étroit et lisse, la Bourgogne 1859 reprend scrupuleusement toutes ces caractéristiques. Seule concession fonctionnelle par rapport à la forme originelle, celle de la hauteur du col : plus long et plus cylindrique, ce profil de col améliore la qualité du bouchage et facilite l'utilisation de longs bouchons comme l'exigent les vins de longue garde.

An authentic "vintage bottle", the Bourgogne 1859 reproduces the original shape of the Burgundy bottle. The same generous proportions, the same slightly asymmetric shoulders, same type of finish, and above all the same very deep punt with slim smooth lines – the Bourgogne 1859 scrupulously retains all these characteristics. The only functional concession in terms of the original shape is the height of the neck: longer and more cylindrical, this neck shape improves the quality of corking and makes it easier to use long corks for wines that require a long aging time.



BOURGOGNE
1859
EXTRA PREMIUM
ORIGINAL DESIGN

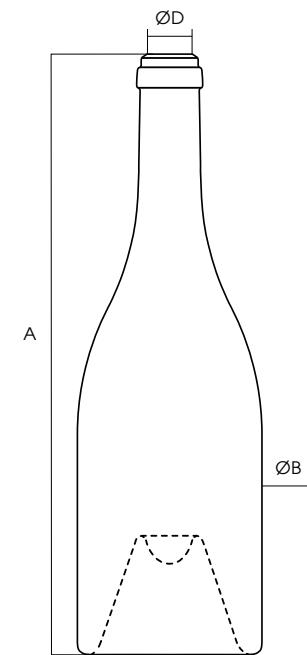

CONTENANCE CAPACITY		75 cl	75 cl	150 cl	150 cl
RÉFÉRENCE REFERENCE		3977 ©	3977 © Sur commande To order	5301 ©	5064 ©
BAGUE FINISH		 Bague Carrée Chardonnay Carrée Chardonnay Finish	 Bague Carrée Chardonnay Carrée Chardonnay Finish	 Bague Carrée Bourgogne Classique Carrée Bourgogne Classique Finish	 Bague Carrée Bourgogne Classique Carrée Bourgogne Classique Finish
POIDS WEIGHT	(g)	830	836	1540	1490
HAUTEUR TOTALE TOTAL HEIGHT	A (mm)	303	303	367.4	367.4
Ø CORPS BODY Ø	B (mm)	92.7	92.7	116.6	115.9
Ø DÉBOUCHAGE ENTRANCE BORE	D (mm)	18.5	18.5	18.5	18.5
TEINTE GLASS COLOUR		● ○	●	●	○

○ : Extra Blanc / Extra White Flint ● : Antique / Antique Green

© : Modèle déposé "Design Saverglass" / © : Registered "Design Saverglass"

BOURGOGNES IMPÉRIALES

EXTRA PREMIUM



BOURGOGNES IMPÉRIALES
EXTRA PREMIUM
ORIGINAL DESIGN



Créées pour révéler la prestance exceptionnelle et la noblesse des plus grands vins, **LA DIVINE** et **LA BARONNE** sont dotées de magnifiques atours : elles captivent par leur port altier et leur silhouette aristocratique et bénéficient de poids généreux, de piqûres profondes voire très profondes et de bagues distinctives inspirées de notre héritage historique.

Created to showcase the exceptional poise and nobility of the greatest wines, **LA DIVINE** and **LA BARONNE** have magnificent features: they are captivating in their majestic stature, aristocratic silhouette, heavy weight, deep to very deep punts, and distinctive finishes inspired by our historical heritage.

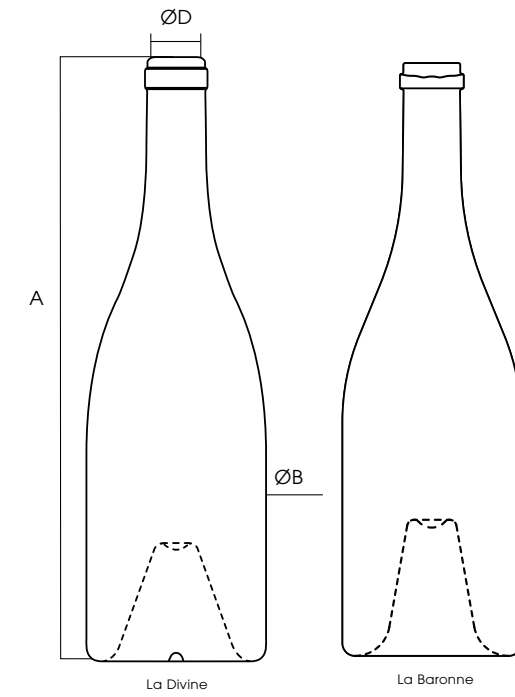

LA DIVINE LA BARONNE LA BARONNE BVS

CONTENANCE CAPACITY		75 cl	75 cl	75 cl
RÉFÉRENCE REFERENCE		3219 ©	2770 ©	4044 © Sur commande To order
BAGUE FINISH		 Bague Carrée Bourgogne Classique Carrée Bourgogne Classique Finish	 Bague Plate Déformée Deformed Cork Mouth Finish	 Bague BVS 31.5H60 BVS 31.5H60 Finish
POIDS WEIGHT	(g)	1005	950	960
HAUTEUR TOTALE TOTAL HEIGHT	A (mm)	308.9	305	305
Ø CORPS BODY Ø	B (mm)	92	92	92
Ø DÉBOUCHAGE ENTRANCE BORE	D (mm)	18.5	18.5	20.5
TEINTE GLASS COLOUR		●	●	●

● : Antique / Antique Green

© : Modèle déposé "Design Saverglass" / © : Registered "Design Saverglass"

BOURGOGNE BOURGEOISE

SUPER PREMIUM



BOURGOGNE
BOURGEOISE
SUPER PREMIUM
ORIGINAL DESIGN



À la manière d'un classique revisité, le modèle **BOURGEOISE** possède tous les atouts pour valoriser des vins fins et authentiques. Il combine harmonieusement une haute stature, une bague cordon et une ligne inédite et élancée.

In the manner of a revisited classic, the **BOURGEOISE** has all the features to showcase fine and authentic wines. It harmoniously combines tall stature, a Cordon finish and a strikingly sleek outline.

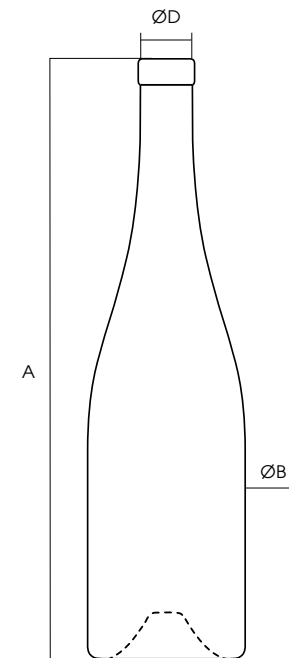

	BOURGEOISE	BOURGEOISE	BOURGEOISE BVS
CONTENANCE CAPACITY	75 cl	75 cl	75 cl
RÉFÉRENCE REFERENCE	1847 ©	1847 ©	4947 © Sur commande To order
BAGUE FINISH	 Bague Cordon Cordon Finish	 Bague Plate FA Plate FA Finish	 Bague BVS 30H60 BVS 30H60 Finish
POIDS WEIGHT (g)	783	785	785
HAUTEUR TOTALE TOTAL HEIGHT A (mm)	322.7	324.7	324.7
Ø CORPS BODY Ø B (mm)	85	85	83.7
Ø DÉBOUCHAGE ENTRANCE BORE D (mm)	18.5	18.5	19
TEINTE GLASS COLOUR	●	● ○	●

○ : Extra Blanc / Extra White Flint ● : Antique / Antique Green

© : Modèle déposé "Design Saverglass" / © : Registered "Design Saverglass"

BOURGOGNE CÉLESTE

SUPER PREMIUM



Illustration remarquable de l'alliance de la force et de l'élégance, la Bourgogne **CÉLESTE** s'inscrit dans la collection des bouteilles haut de gamme réalisées par Saverglass. Charismatique, ce flacon séduit par ses attributs uniques : une hauteur de 300 mm qui le distingue de la forme bourgogne classique, une piqûre profonde de 40 mm parée d'une boudine, une bague carrée bourgogne et enfin, un poids de verre raisonnable de 750 g. Combinant avec habileté classicisme et authenticité, la Bourgogne **CÉLESTE** propose ainsi un modèle de grande facture dédié aux grands crus et conforme à une exploitation sur ligne.

A remarkable illustration of the blend of strength and elegance, the Bourgogne **CÉLESTE** is part of the upscale range of bottles made by Saverglass. This charismatic flask offers a seductive range of features including its 300mm height, which distinguishes it from the classic Burgundy shape, a deep 40mm punt with a "boudine", a square Burgundy collar and a very reasonable 750g glass weight.

Smoothly combining classic and authentic, the Bourgogne **CÉLESTE** offers meticulous craftsmanship dedicated to great vintages and well suited to production line operation.

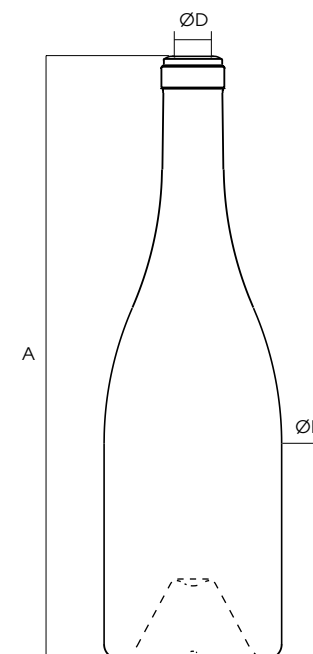

BOURGOGNE
CÉLESTE
SUPER PREMIUM
ORIGINAL DESIGN



CÉLESTE

CONTENANCE
CAPACITY

75 cl

RÉFÉRENCE
REFERENCE

5357

BAGUE
FINISH



Bague Carrée Bourgogne
Carrée Bourgogne Finish

POIDS
WEIGHT

(g)

750

HAUTEUR TOTALE
TOTAL HEIGHT

A (mm)

300

Ø CORPS
BODY Ø

B (mm)

89

Ø DÉBOUCHAGE
ENTRANCE BORE

D (mm)

18.5

TEINTE

GLASS COLOUR

● ○

○ : Extra Blanc / Extra White Flint

● : Antique / Antique Green

BOURGOGNE MAXIMA

SUPER PREMIUM



BOURGOGNE
MAXIMA
SUPER PREMIUM
ORIGINAL DESIGN

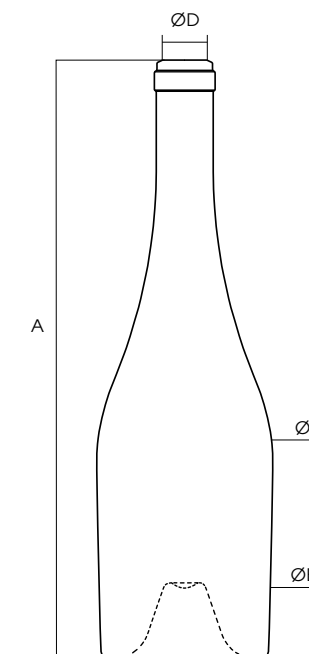

Le modèle **MAXIMA** puise son style unique et élancé, particulièrement élégant, au travers de son épaulement placé spécialement bas et l'exceptionnelle longueur gracieuse de son col. Ce modèle révèle un design résolument moderne, ergonomique, et donc idéalement adapté aux manipulations bourguignonnes classiques.

MAXIMA draws its unique, sleek, particularly elegant style from its distinctively low shoulder and its exceptionally long graceful neck. This model reveals a proudly modern, ergonomic design ideally suited to handling classic Burgundies.



MAXIMA MAXIMA MAXIMA MAXIMA MAXIMA

CONTENANCE CAPACITY		75 cl	75 cl	150 cl	150 cl	300 cl
RÉFÉRENCE REFERENCE		4979 ©	4979 ©	5189 ©	5189 ©	5208 ©
BAGUE FINISH		Bague Carrée Bourgogne Classique Carrée Bourgogne Classique Finish	Bague Plate FA Plate FA Finish	Bague Carrée Bourgogne Classique Carrée Bourgogne Classique Finish	Bague Plate FA Plate FA Finish	Bague Plate FA Plate FA Finish
POIDS WEIGHT	(g)	818	815	1282	1280	2150
HAUTEUR TOTALE TOTAL HEIGHT	A (mm)	315	312.6	382.4	380	474.9
Ø PIED BASE Ø	B (mm)	88.4	88.4	109.7	109.7	135.6
Ø ÉPAULE SHOULDER Ø	C (mm)	93.1	93.1	115.6	115.6	143
Ø DÉBOUCHAGE ENTRANCE BORE	D (mm)	18.5	18.5	18.5	18.5	24
TEINTE GLASS COLOUR		● ○	● ○	●	● ○	● ○

○ : Extra Blanc / Extra White Flint ● : Antique / Antique Green

© : Modèle déposé "Design Saverglass" / © : Registered "Design Saverglass"

BOURGOGNE SABINE

SUPER PREMIUM



SABINE déploie des courbes fluides et ultra-féminines dans un style sans cesse renouvelé au gré des différents types de bagues proposées. Stylée, innovante et contemporaine, la gamme **SABINE** siéra avec perfection aux vins de cépages, aux rosés (dans sa version Extra Blanc) ou aux vins du Nouveau Monde.

SABINE offers flowing ultra-feminine curves in a continuously renewed style by using different types of finishes. Stylish, innovative and contemporary, the **SABINE** range is perfect for vintage wines, rosés (in its Extra White version), and New World wines.

BOURGOGNE
SABINE
SUPER PREMIUM
ORIGINAL DESIGN

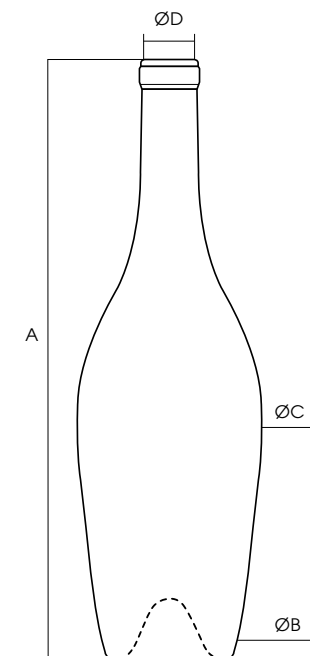

SABINE



SABINE

CONTENANCE
CAPACITY

75 cl

75 cl

RÉFÉRENCE
REFERENCE

2638 ©

2638 ©

BAGUE
FINISH



Bague Fleur
Fleur Finish



Bague Plate Unique
Plate Unique Finish

POIDS
WEIGHT (g)

720

700

HAUTEUR TOTALE
TOTAL HEIGHT A (mm)

319

306.3

Ø PIED
BASE Ø B (mm)

77.5

77.5

Ø ÉPAULE
SHOULDER Ø C (mm)

93.3

93.3

Ø DÉBOUCHAGE
ENTRANCE BORE D (mm)

18.5

18.5

TEINTE
GLASS COLOUR

● ○

●¹ ○

○ : Extra Blanc / Extra White Flint ● : Antique / Antique Green ¹ : Sur commande / To order

© : Modèle déposé "Design Saverglass" / © : Registered "Design Saverglass"

BOURGOGNES TENDANCE

SUPER PREMIUM



BOURGOGNES
TENDANCE
SUPER PREMIUM
ORIGINAL DESIGN

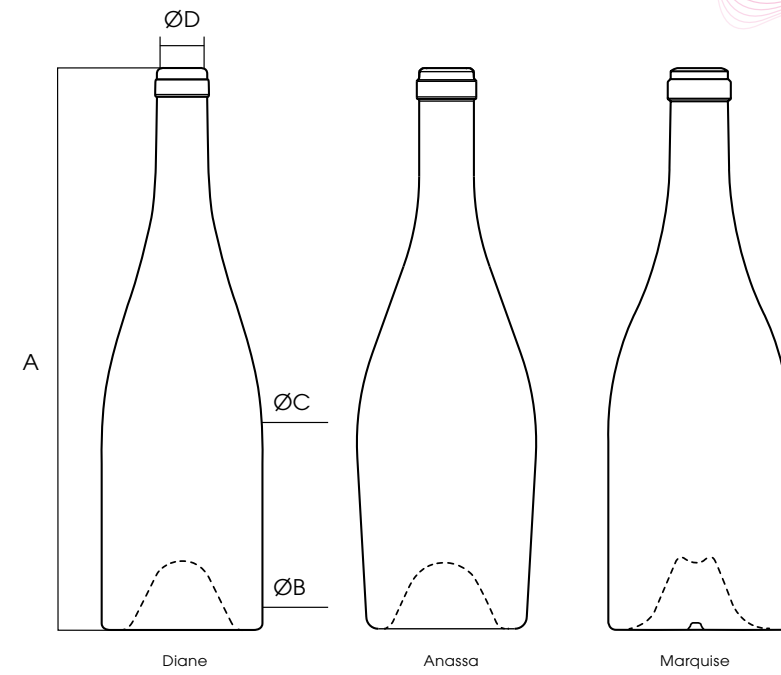

DIANE, ANASSA et **MARQUISE** composent une gamme originale à l'élégance toute contemporaine. Avec leurs épaules amples et leurs formes pleines, **ANASSA** et **MARQUISE** proposent des silhouettes opulentes et trapues. Si **ANASSA** présente une franche conicité du fût et une bague carrée, **MARQUISE** se distingue par un long col cylindrique et une piqûre profonde parée d'une boudine. **DIANE**, fait rare pour une bourguignonne, brille quant à elle par sa haute stature et par une silhouette gracile, qui lui assure une excellente visibilité en points de vente ou sur une table.

DIANE, ANASSA and **MARQUISE** comprise an original range with totally contemporary elegance. With their wide shoulders and full shapes, **ANASSA** and **MARQUISE** offer opulent and stocky silhouettes. While **ANASSA** offers a strikingly tapered base and square fins, **MARQUISE** stands out by its long cylindrical neck and its deep punt with a "boudine". **DIANE**, rare for a Burgundy, stands out due to its tall, graceful silhouette, which guarantees it excellent visibility in-store or on a table.



DIANE ANASSA MARQUISE MARQUISE

CONTENANCE CAPACITY		75 cl	75 cl	75 cl	75 cl
RÉFÉRENCE REFERENCE		3556 ©	3555 ©	4374 ©	4374 © Sur commande To order
BAGUE FINISH		 Bague Plate Unique Plate Unique Finish	 Bague Carrée Chardonnay Carrée Chardonnay Finish	 Bague Carrée Bourgogne Classique Carrée Bourgogne Classique Finish	 Bague Carrée Chardonnay Carrée Chardonnay Finish
POIDS WEIGHT	(g)	810	810	800	800
HAUTEUR TOTALE TOTAL HEIGHT	A (mm)	311.5	297.4	285	285.4
Ø PIED BASE Ø	B (mm)	88.9	85	92.4	92.4
Ø ÉPAULE SHOULDER Ø	C (mm)	88.9	95	92.4	92.4
Ø DÉBOUCHAGE ENTRANCE BORE	D (mm)	18.5	18.5	18.5	18.5
TEINTE GLASS COLOUR		●	●	● ○	● ○

○ : Extra Blanc / Extra White Flint ● : Antique / Antique Green

© : Modèle déposé "Design Saverglass" / © : Registered "Design Saverglass"

BOURGOGNES PERSONNALISÉES

SUPER PREMIUM



En complément des versions standard « lisses », certains de nos modèles sont proposés dans une version « PERSONNALISABLE » au moyen d'un médaillon gravé à l'épaule. Cette formule raffinée d'écussonnage s'avère extrêmement fidèle au plan du rendu verre de la gravure et particulièrement économique en termes de frais de développement.

In addition to the standard "smooth" versions, some of our models are offered in a "PERSONALIZABLE" version in the form of an engraved locket on the shoulder. This refined approach, capitalizing on the quality of the design, is extremely efficient in terms of glass use and very economical in terms of development costs.

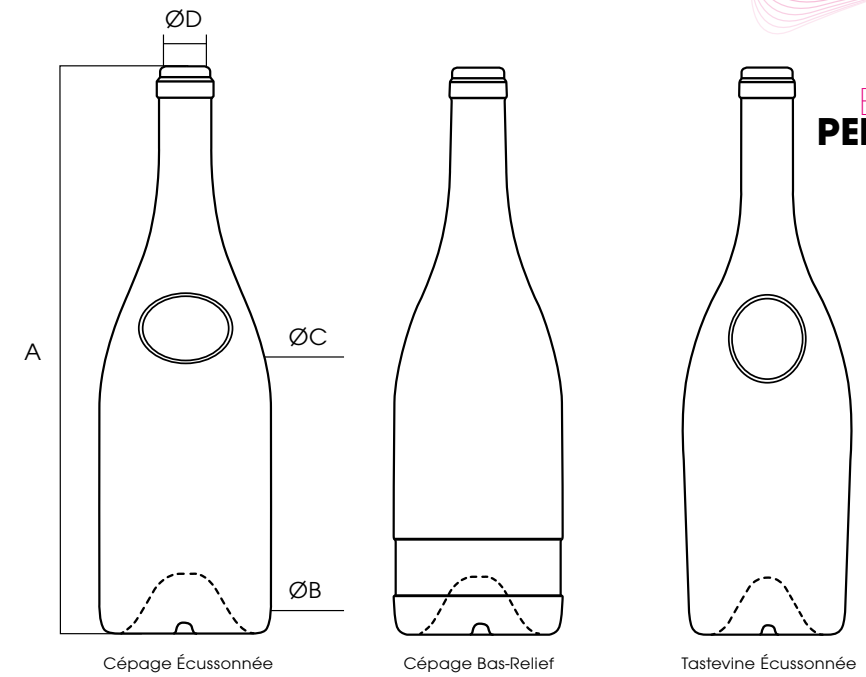

BOURGOGNES PERSONNALISÉES
SUPER PREMIUM
ORIGINAL DESIGN



CÉPAGE ÉCUSSONNÉE

CÉPAGE BAS-RELIEF

TASTEVINE ÉCUSSONNÉE

CONTENANCE CAPACITY		75 cl	75 cl	75 cl
RÉFÉRENCE REFERENCE		2105 © Sur commande To order	2708 © Sur commande To order	2793 © Sur commande To order
BAGUE FINISH		 Bague Plate Unique Plate Unique Finish	 Bague Plate Unique Plate Unique Finish	 Bague Plate Unique Plate Unique Finish
POIDS WEIGHT	(g)	700	690	675
HAUTEUR TOTALE TOTAL HEIGHT	A (mm)	296	295.5	300
Ø PIED BASE Ø	B (mm)	87.8	87.8	83.8
Ø ÉPAULE SHOULDER Ø	C (mm)	87.8	87.8	89.3
Ø DÉBOUCHAGE ENTRANCE BORE	D (mm)	18.5	18.5	18.5
TEINTE GLASS COLOUR		●	●	●

● : Antique / Antique Green

© : Modèle déposé "Design Saverglass" / © : Registered "Design Saverglass"

BOURGOGNES CHARDONNAY & ATLAS

PREMIUM ORIGINAL DESIGN

CHARDONNAY emprunte son nom à l'un des cépages les plus réputés au monde. Associant classicisme et authenticité, ce modèle impose son fort tempérament en s'appuyant notamment sur une belle bague carrée. Résolument moderne, la version BVS 31.5H60 reste extrêmement fonctionnelle.

À l'image de la Bourgogne CHARDONNAY, **ATLAS** offre une silhouette généreuse qui l'apparente aux lourds flacons d'autrefois.



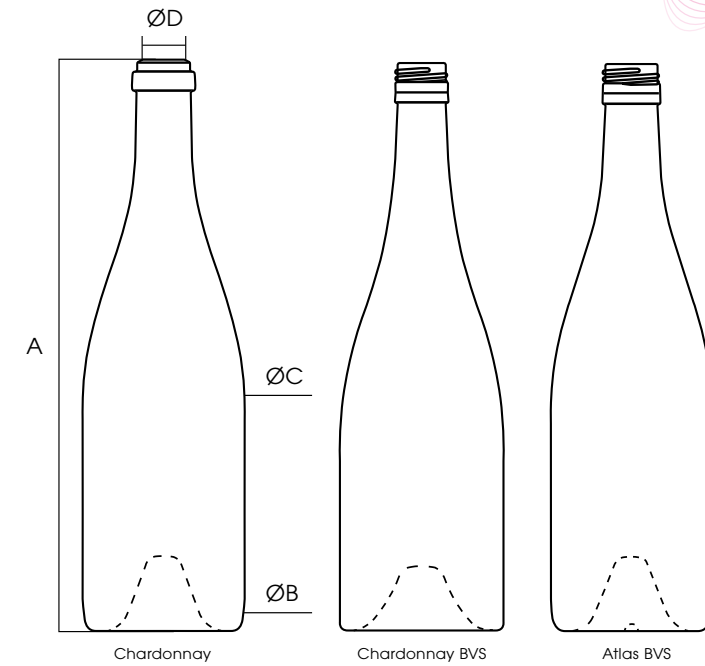

CHARDONNAY takes its name from one of the most famous grapes in the world. Combining classic style and authenticity, this model stands out with its strong temperament displayed in its beautiful square finish. Although proudly modern, the BVS 31.5H60 version remains extremely functional.

Like the Bourgogne CHARDONNAY, **ATLAS** offers a generous silhouette that evokes the heavy bottles of times past.



BOURGOGNES
CHARDONNAY
& ATLAS
PREMIUM ORIGINAL DESIGN



CONTENANCE CAPACITY		75 cl	75 cl	75 cl	75 cl
RÉFÉRENCE REFERENCE		2315 ©	2315 ©	4133 © Sur commande To order	3618 ©
BAGUE FINISH		 Bague Carrée Chardonnay Carrée Chardonnay Finish	 Bague Carrée Bourgogne Classique Carrée Bourgogne Classique Finish	 Bague BVS 31.5H60 BVS 31.5H60 Finish	 Bague BVS 30H60 BVS 30H60 Finish
POIDS WEIGHT	(g)	850	850	865	820
HAUTEUR TOTALE TOTAL HEIGHT	A (mm)	306	305.3	306	310
Ø PIED BASE Ø	B (mm)	86.6	86.6	86.6	89
Ø ÉPAULE SHOULDER Ø	C (mm)	86.6	86.6	86.6	89
Ø DÉBOUCHAGE ENTRANCE BORE	D (mm)	18.5	18.5	20.5	19
TEINTE GLASS COLOUR		○ ¹ ● ● ¹	●	●	●

○ : Extra Blanc / Extra White Flint ● : Antique / Antique Green ● : Champagne / Champagne Green ¹ : Sur commande / To order

© : Modèle déposé "Design Saverglass" / © : Registered "Design Saverglass"

BOURGOGNE GRAVILLE

PREMIUM

PREMIUM
DESIGN



Référence dans la catégorie des bourguignonnes premium, l'opulente **GRAVILLE** est reconnaissable entre toutes. On aime son épaule ample et galbée, son corps puissant et son jable prononcé. Pour renouveler subtilement son style, diverses options de bouchages sont disponibles.

Leading the way in the Premium Burgundian category, the opulent **GRAVILLE** is immediately recognizable. It is prized for its full rounded shoulder, powerful body and pronounced heel. Subtle updates to its style include various closure options.

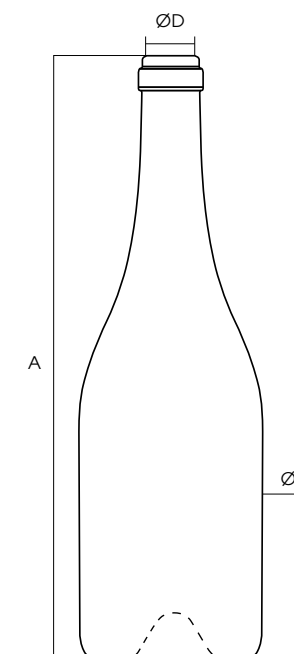

GRAVILLE

CONTENANCE
CAPACITY

75 cl

RÉFÉRENCE
REFERENCE

T045 ©

BAGUE
FINISH



Bague Plate Unique
Plate Unique Finish

POIDS
WEIGHT

(g)

655

HAUTEUR TOTALE
TOTAL HEIGHT

A (mm)

295

Ø CORPS
BODY Ø

B (mm)

88.6

Ø DÉBOUCHAGE
ENTRANCE BORE

D (mm)

18.5

TEINTE
GLASS COLOUR



● : Antique / Antique Green

© : Modèle déposé "Design Saverglass" / © : Registered "Design Saverglass"

BOURGOGNE
GRAVILLE
PREMIUM

PREMIUM
DESIGN

BOURGOGNE JUSTINE

PREMIUM



BOURGOGNE
JUSTINE
PREMIUM



Grâce à une épaule plus franche au trait légèrement oblique, la Bourgogne **JUSTINE** se positionne comme une version modernisée de la Bourgogne TRADITION.

Dotée d'une piqûre de profil carré et d'un rayon de jable nerveux, le style géométrique de **JUSTINE** bouscule assurément les codes esthétiques traditionnels. Elle est également dotée d'un poids de verre raisonnable lui conférant une plus grande attractivité.

With its more straightforward shoulder and slightly oblique lines, the Bourgogne **JUSTINE** positions itself as a modernized version of the Bourgogne TRADITION.

Featuring a square cross-section punt and racy heel diameter, the geometric style of **JUSTINE** has clearly upended traditional aesthetic standards. Its reasonable glass weight makes it all the more attractive.

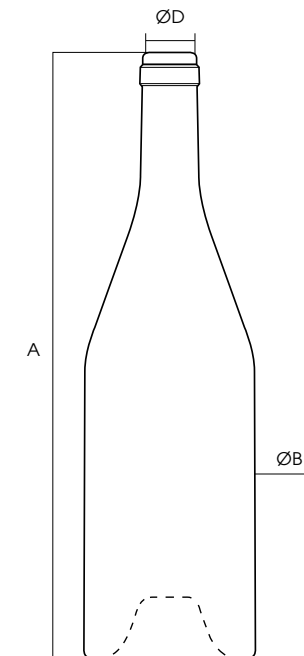

JUSTINE

CONTENANCE
CAPACITY

75 cl

RÉFÉRENCE
REFERENCE

4132 ©

BAGUE
FINISH



Bague Plate Unique
Plate Unique Finish

POIDS
WEIGHT

(g)

600

HAUTEUR TOTALE
TOTAL HEIGHT

A (mm)

297

Ø CORPS
BODY Ø

B (mm)

83.2

Ø DÉBOUCHAGE
ENTRANCE BORE

D (mm)

18.5

TEINTE

GLASS COLOUR

● ○

○ : Extra Blanc / Extra White Flint ● : Antique / Antique Green

© : Modèle déposé "Design Saverglass" / © : Registered "Design Saverglass"

BOURGOGNE TASTEVINE

PREMIUM



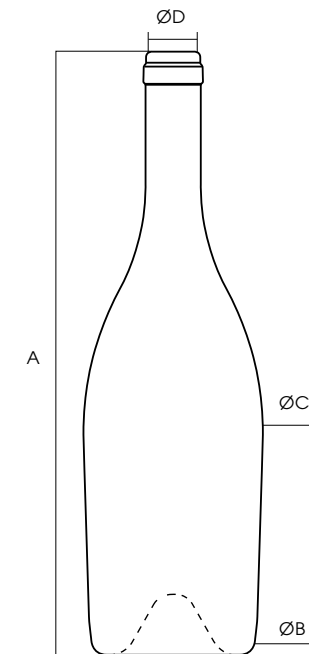

TASTEVINE emprunte son nom au vocabulaire des confréries bachiques. Ses contours harmonieux jouent l'accord parfait entre un fût à la forme délicatement conique, des épaules galbées prolongées par un long col insufflant à l'ensemble une touche de légèreté.

TASTEVINE takes its name from the wine-tasting fraternity. The harmony of its shape with its subtly tapered body and rounded shoulders extending into a long neck, imbue the bottle with a touch of lightness.



TASTEVINE

TASTEVINE

CONTENANCE CAPACITY		75 cl	150 cl
RÉFÉRENCE REFERENCE		2296 ©	3386 ©
BAGUE FINISH		 Bague Plate Unique Plate Unique Finish	 Bague Carrée Spéciale Special Carrée Finish
POIDS WEIGHT	(g)	675	1150
HAUTEUR TOTALE TOTAL HEIGHT	A (mm)	300	360
Ø PIED BASE Ø	B (mm)	83.8	105
Ø ÉPAULE SHOULDER Ø	C (mm)	89.3	114.5
Ø DÉBOUCHAGE ENTRANCE BORE	D (mm)	18.5	18.5
TEINTE GLASS COLOUR		● ○	● ○

○ : Extra Blanc / Extra White Flint ● : Antique / Antique Green

© : Modèle déposé "Design Saverglass" / © : Registered "Design Saverglass"

BOURGOGNE VIN GRAND CRU

PREMIUM



BOURGOGNE
VIN GRAND CRU
PREMIUM



Les bouteilles de la gamme **VIN GRAND CRU** se sont naturellement imposées comme des conditionnements d'exception grâce à leur silhouette caractéristique : un corps trapu et une épaule tombante que prolonge un col exceptionnellement long s'étirant à « l'infini ». Un design soigné et merveilleusement intemporel destiné à sublimer le vin.

Bottles in the **VIN GRAND CRU** range epitomize luxury with their characteristic silhouette: short wide bodies with elegant sloping shoulders to accentuate the unusually long necks stretching upward to infinity. This delicate and marvelously timeless design will enhance any wine.

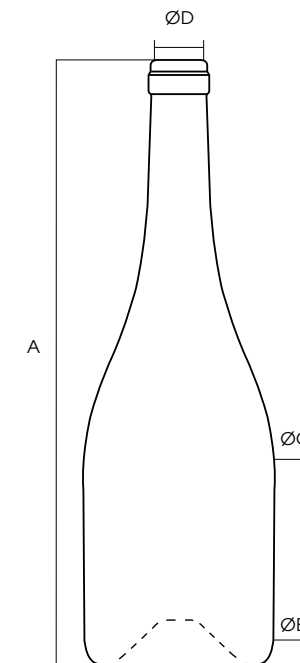

CONTENANCE CAPACITY		75 cl	75 cl	75 cl	150 cl
RÉFÉRENCE REFERENCE		0604 © Sur commande To order	0604 © Sur commande To order	0604 ©	2404 ©
BAGUE FINISH		 Bague Flange Flange Finish	 Bague Plate FA Plate FA Finish	 Bague Plate Unique Plate Unique Finish	 Bague Carrée Carrée Finish
POIDS WEIGHT	(g)	678	685	685	1170
HAUTEUR TOTALE TOTAL HEIGHT	A (mm)	284.4	292	294	360
Ø PIED BASE Ø	B (mm)	91.7	91.7	91.7	114.6
Ø ÉPAULE SHOULDER Ø	C (mm)	92.7	92.7	92.7	115.8
Ø DÉBOUCHAGE ENTRANCE BORE	D (mm)	18.5	18.5	18.5	21
TEINTE GLASS COLOUR		●	●	●	●

● : Antique / Antique Green

© : Modèle déposé "Design Saverglass" / © : Registered "Design Saverglass"

BOURGOGNES CÉPAGE & AGAPE

STANDARD PREMIUM



BOURGOGNES
CÉPAGE
& AGAPE
STANDARD PREMIUM
CLASSIC DESIGN

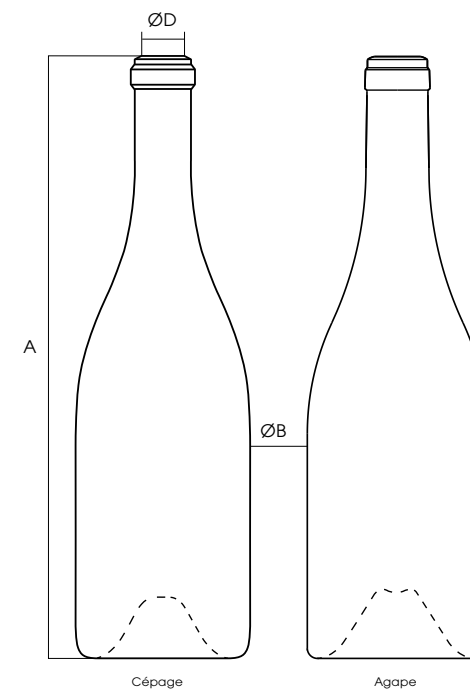

L'élégante silhouette classique de son design permet à la gamme **CÉPAGE** de conjuguer fonctionnalité, grâce et distinction soit autant de qualités qui répondent aux exigences des vins de garde.

La Bourgogne **AGAPE** affiche une version moderne de la silhouette bourguignonne. Un corps cylindrique, une bague carrée bourgogne et une piqûre distinctive constituent un ensemble idéalement rythmé, dessiné dans le souci du détail et d'une grande praticité.

The elegantly classic silhouette of the design of the **CÉPAGE** range combines functionality, grace and distinction, the essential qualities required for wines meant for cellaring.

The Bourgogne **AGAPE** offers a modern version of the traditional Burgundian style. A cylindrical body, a carrée bourgogne finish and a distinctive punt offer an optimally balanced ensemble, designed with attention to detail for full functionality.



	CÉPAGE	CÉPAGE	CÉPAGE	AGAPE	AGAPE	AGAPE
CONTENANCE CAPACITY	75 cl	75 cl	75 cl	37.5 cl	75 cl	150 cl
RÉFÉRENCE REFERENCE	1462 ©	1462 © Sur commande To order	1462 ©	5759	5065	5760
BAGUE FINISH	Bague Carrée Bourgogne Carrée Bourgogne Finish	Bague Flange Flange Finish	Bague Plate Unique Plate Unique Finish	Bague Carrée Bourgogne Carrée Bourgogne Finish	Bague Carrée Bourgogne Carrée Bourgogne Finish	Bague Carrée Bourgogne Carrée Bourgogne Finish
POIDS WEIGHT (g)	700	695	700	390	700	1250
HAUTEUR TOTALE TOTAL HEIGHT A (mm)	296	286.4	295.6	233.2	296.1	368.1
Ø CORPS BODY Ø B (mm)	87.8	87.8	87.8	68.9	88.7	111.7
Ø DÉBOUCHAGE ENTRANCE BORE D (mm)	18.5	18.5	18.5	18.5	18.5	18.5
TEINTE GLASS COLOUR	●	●	● ○ ¹	● ○	● ○	● ○

○ : Extra Blanc / Extra White Flint ● : Antique / Antique Green ¹ : Sur commande / To order

© : Modèle déposé "Design Saverglass" / © : Registered "Design Saverglass"

BOURGOGNE ÉLÉGANCE

STANDARD PREMIUM



Le charme de la Bourgogne
ÉLÉGANCE opère infailliblement,
entre beauté, finesse et originalité des
courbes. Cette bouteille ultra féminine, à
la prestance et au chic incomparables,
renforce son piquant grâce à la bague
lotus, une exclusivité de Saverglass.

The charm of the Bourgogne
ÉLÉGANCE unerringly conjures beauty,
finesse and original curves. The lotus
finish (exclusive to Saverglass) embodies
the originality of this resolutely feminine
bottle, which boasts incomparable pre-
sence and style.

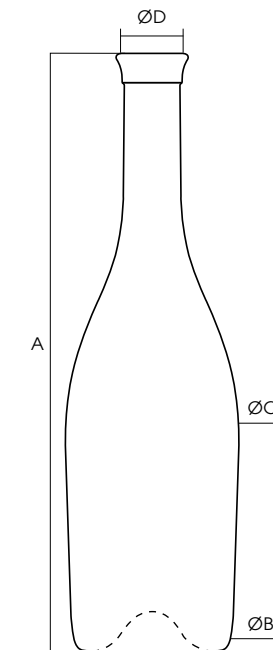



BOURGOGNE
ÉLÉGANCE
STANDARD PREMIUM



ÉLÉGANCE



ÉLÉGANCE

CONTENANCE CAPACITY		75 cl	75 cl
RÉFÉRENCE REFERENCE		T149	T149 Sur commande To order
BAGUE FINISH		 Bague Plate Unique Plate Unique Finish	 Bague Plate VDL Plate VDL Finish
POIDS WEIGHT	(g)	550	545
HAUTEUR TOTALE TOTAL HEIGHT	A (mm)	301	301
Ø PIED BASE Ø	B (mm)	81.2	81.2
Ø ÉPAULE SHOULDER Ø	C (mm)	87	87
Ø DÉBOUCHAGE ENTRANCE BORE	D (mm)	18.5	18.5
TEINTE GLASS COLOUR		○ ¹ ●	○ ● ¹

○: Extra Blanc / Extra White Flint

●: Antique / Antique Green

¹: Sur commande / To order

BOURGOGNE GRAND MILLÉSIME

STANDARD PREMIUM



BOURGOGNE
GRAND MILLÉSIME
STANDARD PREMIUM
CLASSIC DESIGN



La Bourgogne **GRAND MILLÉSIME** revisite avec style la classique silhouette bourguignonne. Ses mensurations équilibrées se prêtent volontiers aux différentes options de bouchage, s'accommodant de l'impressionnante bague carrée spéciale comme de la classique bague cétie.

The Bourgogne **GRAND MILLÉSIME** revisits the classic burgundy silhouette with style. Its balanced measurements lend themselves to the various closure options, accommodating the impressive special carrée finish or the classic cétie type finish.



GRAND MILLÉSIME



GRAND MILLÉSIME



GRAND MILLÉSIME BVS

CONTENANCE CAPACITY		75 cl	75 cl	75 cl
RÉFÉRENCE REFERENCE		1825 ©	1825 ©	2988 ©
BAGUE FINISH		 Bague Plate Unique Plate Unique Finish	 Bague Carrée Bourgogne Carrée Bourgogne Finish	 Bague BVS 30H60 BVS 30H60 Finish
POIDS WEIGHT	(g)	650	655	700
HAUTEUR TOTALE TOTAL HEIGHT	A (mm)	293	293.8	303
Ø CORPS BODY Ø	B (mm)	85.5	85.5	85.5
Ø DÉBOUCHAGE ENTRANCE BORE	D (mm)	18.5	18.5	20
TEINTE GLASS COLOUR		●	●	●

● : Antique / Antique Green

© : Modèle déposé "Design Saverglass" / © : Registered "Design Saverglass"

BOURGOGNES PRESTIGE

STANDARD PREMIUM



Les bouteilles de la gamme **PRESTIGE** (modèles **PRESTIGE** et **SAINT-YVES**) subliment l'image des grands vins et préservent l'héritage de la traditionnelle silhouette bourguignonne en y insufflant modernité et sophistication.

Bottles in the **PRESTIGE** range (**PRESTIGE** and **SAINT-YVES** models) enhance the image of great wines and retain the heritage and Burgundian silhouette, imparting a modern and sophisticated style.

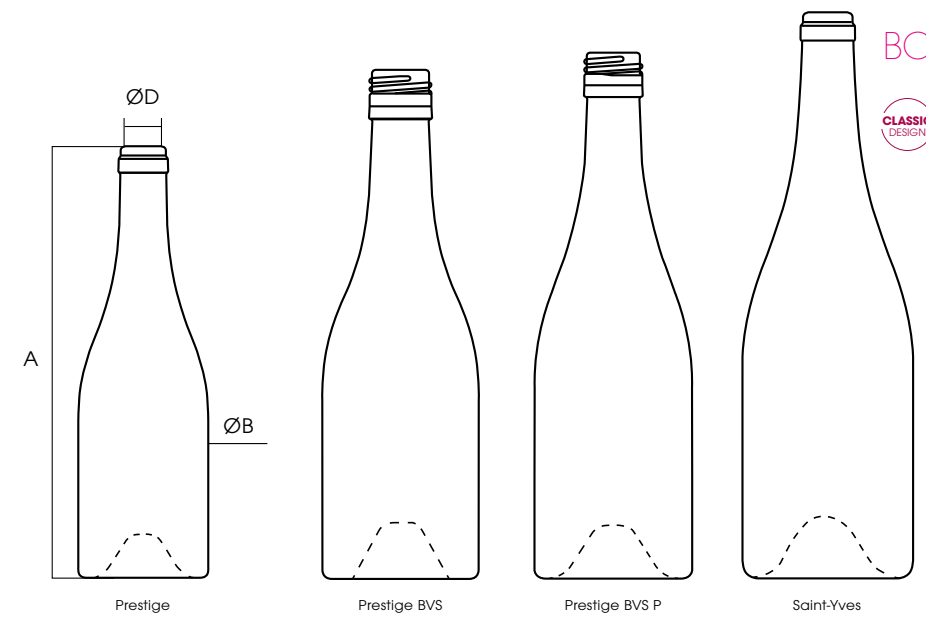

BOURGOGNES
PRESTIGE
STANDARD PREMIUM



PRESTIGE **PRESTIGE BVS** **PRESTIGE** **PRESTIGE BVS P** **SAINT-YVES**

		PRESTIGE	PRESTIGE BVS	PRESTIGE	PRESTIGE BVS P	SAINT-YVES
CONTENANCE CAPACITY		37.5 cl	37.5 cl	50 cl	50 cl	75 cl
RÉFÉRENCE REFERENCE		1893 ©	3649 ©	2158 ©	4340 ©	T200 Sur commande To order
BAGUE FINISH		 Bague Plate Unique Plate Unique Finish	 Bague BVS 30H60 BVS 30H60 Finish	 Bague Plate Unique Plate Unique Finish	 Bague BVS 30H60 BVS 30H60 Finish	 Bague Plate Unique Plate Unique Finish
POIDS WEIGHT	(g)	437	437	540	540	680
HAUTEUR TOTALE TOTAL HEIGHT	A (mm)	232.5	232.5	258.8	258.8	292
Ø CORPS BODY Ø	B (mm)	72	72	77.9	77.6	89.2
Ø DÉBOUCHAGE ENTRANCE BORE D (mm)		18.5	20.5	18.5	20	18.5
TEINTE GLASS COLOUR		●	●	●	●	●

● : Antique / Antique Green

© : Modèle déposé "Design Saverglass" / © : Registered "Design Saverglass"

BOURGOGNES TRADITION

STANDARD PREMIUM



BOURGOGNES TRADITION
CLASSIC DESIGN
STANDARD PREMIUM



Fonctionnelle et idéalement équilibrée, la bouteille Bourgogne **TRADITION** propose un conditionnement sobre et élégant et tient compte des exigences de la profession au travers de son principe de bouchage.

The **BOURGOGNE TRADITION** bottle is both functional and well balanced, offering a clean and elegant outline in harmony with the industry's demands and capping standards.



	CADETTE	TRADITION	TRADITION BVS	CLASSIQUE	CLASSIQUE BVS P	TRADITION	TRADITION	TRADITION	TRADITION BVS	TRADITION	TRADITION
CONTENANCE CAPACITY	50 cl	75 cl	75 cl	75 cl	75 cl	150 cl	150 cl	150 cl	150 cl	300 cl	500 cl
RÉFÉRENCE REFERENCE	1587	1824	4413	1746	4339 Sur commande To order	1835	5311	1179	4833 Sur commande To order	1035	1036
BAGUE FINISH	 Bague Plate Unique Plate Unique Finish	 Bague Plate Unique Plate Unique Finish	 Bague BVS 30H60 BVS 30H60 Finish	 Bague Carrée Bourgogne Carrée Bourgogne Finish	 Bague BVS 31.5H60 BVS 31.5H60 Finish	 Bague Plate Unique Plate Unique Finish	 Bague Carrée Bourgogne Carrée Bourgogne Finish	 Bague Carrée Bourgogne Carrée Bourgogne Finish	 Bague BVS 30H60 BVS 30H60 Finish	 Bague Carrée SB39.5 Carrée SB39.5 Finish	 Bague Carrée SB39.5 Carrée SB39.5 Finish
POIDS WEIGHT (g)	334	600	530	600	600	1100	1000	1158	1076	1530	2700
HAUTEUR TOTALE TOTAL HEIGHT A (mm)	245	296	295	296	296	354.6	354.6	354.6	354.6	437.5	495
Ø CORPS BODY Ø B (mm)	71	82.2	82.2	82.4	82.7	107.5	106	107.5	107.5	131.2	160
Ø DÉBOUCHAGE ENTRANCE BORE D (mm)	18.5	18.5	20	18.5	20	18.5	18.5	21	19	28	28
TEINTE GLASS COLOUR	● ¹	○ ●	○ ●	●	●	● ●	●	●	●	●	●

○ : Extra Blanc / Extra White Flint ● : Antique / Antique Green ● : Feuille Morte / Dead Leaf ● : Champagne / Champagne Green ¹ : Sur commande / To order

BOURGOGNES TRADITION

STANDARD PREMIUM



RÉALISATIONS BOURGOGNES BOURGOGNES PROJECTS



LA DIVINE LA BARONNE

1859

TASTEVINE

MARQUISE AGAPE

SABINE

GRAND
MILLÉSIME

NOUVEAUX NEW CONCEPTS



ESSENCIA WINE	122
FENG WINE	124
GEISHA WINE	126
KENDO WINE	128
MASSALIA	130
SOPHIA	132
THEOS WINE	134
BORDELAISES ÉCLAT	136
CONCEPT INVENT	138



CONCEPT ANTIK	140
---------------------	-----

ESSENCIA WINE

SUPER PREMIUM



Le modèle **ESSENCIA WINE** dessine avec fraîcheur des contours fluides emprunts de modernité et de sensualité. Son bas-fût évasé stabilise une silhouette féminine aux traits vifs qui mêlent grâce et distinction.

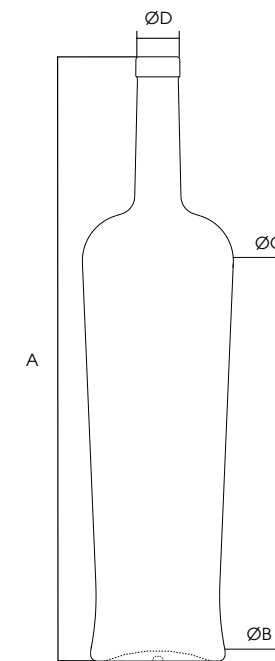

ESSENCIA WINE brings a touch of freshness to the fluid contours, which take their cues from a more modern and sensual source. Its flared base steadies a feminine silhouette of lofty energy that blends grace and distinction.

ESSENCIA WINE
SUPER PREMIUM



ESSENCIA WINE

ESSENCIA WINE

		75 cl	150 cl
CONTENANCE CAPACITY		75 cl	150 cl
RÉFÉRENCE REFERENCE		4852 ©	5452 ©
BAGUE FINISH		 Bague Plate FA Plate FA Finish	 Bague Plate FA Plate FA Finish
POIDS WEIGHT	(g)	700	1180
HAUTEUR TOTALE TOTAL HEIGHT	A (mm)	329	406
Ø PIED BASE Ø	B (mm)	72.5	101.5
Ø ÉPAULE SHOULDER Ø	C (mm)	81.4	90.4
Ø DÉBOUCHAGE ENTRANCE BORE	D (mm)	18.5	18.5
TEINTE GLASS COLOUR		● ○	○

○ : Extra Blanc / Extra White Flint ● : Antique / Antique Green

© : Modèle déposé "Design Saverglass" / © : Registered "Design Saverglass"

FENG WINE

SUPER PREMIUM



Moins provocante que la silhouette KENDO, la forme du modèle **FENG WINE** offre des particularités esthétiques et fonctionnelles plus en rapport avec son unique vocation de bouteille de vin. Ses proportions plus académiques, son épaule plus oblique, son fût cylindrique et sa piqûre de profil carré inscrivent clairement la bouteille dans l'univers du vin, sans altérer pour autant la vivacité et la puissance de son design.

Less provocative than the KENDO silhouette, the shape of the **FENG WINE** exhibits aesthetic and functional characteristics which are in line with its use for wines. Its more conventional proportions, its slanted shoulder, its cylindrical body and its square punt, place the bottle unmistakably in the world of wines, without diminishing in any way the vivacity and the power of its design.



FENG WINE
SUPER PREMIUM

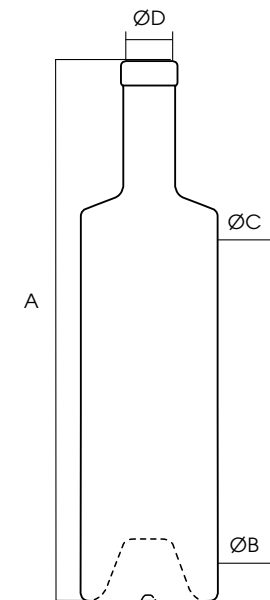

FENG WINE

CONTENANCE CAPACITY		75 cl
RÉFÉRENCE REFERENCE		3781 ©
BAGUE FINISH		 Bague Plate FA Plate FA Finish
POIDS WEIGHT	(g)	710
HAUTEUR TOTALE TOTAL HEIGHT	A (mm)	305
Ø PIED BASE Ø	B (mm)	77.4
Ø ÉPAULE SHOULDER Ø	C (mm)	77.4
Ø DÉBOUCHAGE ENTRANCE BORE	D (mm)	18.5
TEINTE GLASS COLOUR		● ○

○ : Extra Blanc / Extra White Flint ● : Antique / Antique Green

© : Modèle déposé "Design Saverglass" / © : Registered "Design Saverglass"

GEISHA WINE

SUPER PREMIUM



GEISHA WINE est un flacon qui apporte une vraie différenciation esthétique. Son design résolument moderne inspire le raffinement et l'élégance. Il marie de manière très harmonieuse la douceur du fût galbé et son épaulement vif et étroit. Avant-gardiste, il porte fièrement la signature Saverglass.

GEISHA WINE is a bottle that brings about a true aesthetic discrimination. Its resolutely modern design inspires refinement and elegance. It combines most harmoniously the sensuality of a curved body and a sharp, narrow shoulder. This avant-garde model proudly bears the Saverglass signature.

GEISHA WINE
SUPER PREMIUM
ORIGINAL DESIGN

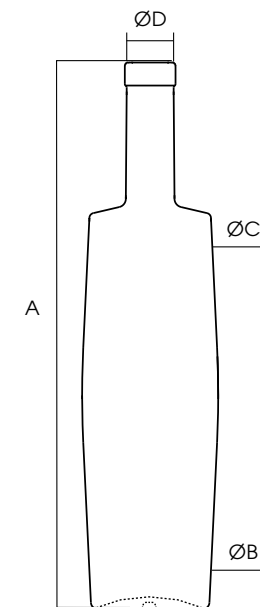

GEISHA WINE

CONTENANCE
CAPACITY

75 cl

RÉFÉRENCE
REFERENCE

4991 ©

BAGUE
FINISH



Bague Plate FA
Plate FA Finish

POIDS
WEIGHT

(g)

772

HAUTEUR TOTALE
TOTAL HEIGHT

A (mm)

320

Ø PIED
BASE Ø

B (mm)

69.4

Ø ÉPAULE
SHOULDER Ø

C (mm)

71.2

Ø DÉBOUCHAGE
ENTRANCE BORE

D (mm)

18.5

TEINTE

GLASS COLOUR

● ○

○ : Extra Blanc / Extra White Flint ● : Antique / Antique Green

© : Modèle déposé "Design Saverglass" / © : Registered "Design Saverglass"

KENDO WINE

SUPER PREMIUM



KENDO WINE
SUPER PREMIUM
ORIGINAL DESIGN



Interprétation audacieuse et rupturiste de la forme bordelaise, **KENDO WINE** emprunte ses lignes graphiques à l'univers des spiritueux. Avec un léger cintrage du corps, des épaules vives et une semelle de verre plate, **KENDO WINE** signe une bouteille au design avant-gardiste dans le monde du vin. Innovante, cette bouteille offre des possibilités d'habillage et de bouchage inédits, et propose un écrin parfaitement adapté aux nouvelles tendances de consommation.

KENDO WINE is a bold interpretation that departs from the traditional Bordeaux design, borrowing its graphic lines from the world of liquor. Its slightly curved body, taut shoulders and a flat glass base give **KENDO WINE** a distinctive avant-garde shape in the winemaking industry. With its innovative profile, this bottle offers potential for inventive presentation and closure, and paves the way for new consumer trends.

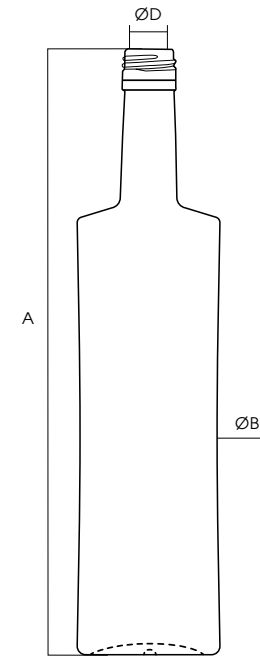

CONTENANCE CAPACITY		25 cl	75 cl	75 cl
RÉFÉRENCE REFERENCE		3751 ©	3340 ©	3753 ©
BAGUE FINISH		 Bague BVP 25H43 BVP 25H43 Finish	 Bague Plate FA Plate FA Finish	 Bague BVS 30H60 BVS 30H60 Finish
POIDS WEIGHT	(g)	280	680	706
HAUTEUR TOTALE TOTAL HEIGHT	A (mm)	216.5	320	320
Ø CORPS BODY Ø	B (mm)	54.5	75.7	75.9
Ø DÉBOUCHAGE ENTRANCE BORE	D (mm)	16.5	18.5	20
TEINTE GLASS COLOUR		● ○	● ○	● ○

○ : Extra Blanc / Extra White Flint ● : Antique / Antique Green

© : Modèle déposé "Design Saverglass" / © : Registered "Design Saverglass"

MASSALIA

SUPER PREMIUM



À la fois sophistiquée et simplissime, innovante et évidente, dynamique et sensuelle, **MASSALIA** cultive à plaisir les contraires. Sa singularité réside dans sa forme conique inversée. Son élégance fluide résulte de sa belle stature et d'une parfaite justesse de proportions. Son caractère féminin est souligné par la rondeur de l'épaule et une espiègle piqûre en forme d'ogive.

Sophisticated yet extremely pure, innovative yet simple, dynamic yet sensuous, **MASSALIA** indulges itself in contradictions. Its uniqueness comes from its inverted tapered shape. Its flowing elegance comes from its attractive stature and its well-balanced proportions. Its feminine character is underlined by the roundness of its shoulder and a bullet shaped punt.

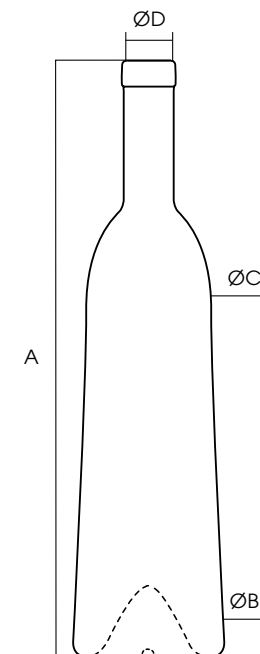

MASSALIA

CONTENANCE
CAPACITY

75 cl

RÉFÉRENCE
REFERENCE

3776 ©

BAGUE
FINISH



Bague Plate FA
Plate FA Finish

POIDS
WEIGHT

(g)

715

HAUTEUR TOTALE
TOTAL HEIGHT

A (mm)

330

Ø PIED
BASE Ø

B (mm)

83.4

Ø ÉPAULE
SHOULDER Ø

C (mm)

68.4

Ø DÉBOUCHAGE
ENTRANCE BORE

D (mm)

18.5

TEINTE
GLASS COLOUR

● ○

○ : Extra Blanc / Extra White Flint ● : Antique / Antique Green

© : Modèle déposé "Design Saverglass" / © : Registered "Design Saverglass"

MASSALIA
SUPER PREMIUM
ORIGINAL DESIGN

SOPHIA

SUPER PREMIUM

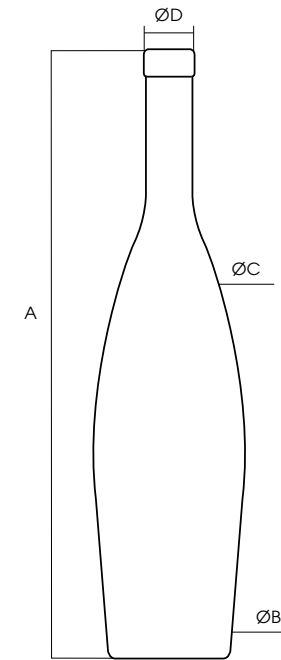

Le modèle **SOPHIA** affiche un style moderne et ludique. Dotée d'une semelle de verre singulière faisant effet de piédestal, la charismatique **SOPHIA** déploie des lignes féminines combinant un fût harmonieusement galbé à un col long et cylindrique surmonté d'une bague plate.

SOPHIA offers a modern playful style. Its singular glass base forms a kind of pedestal, while **SOPHIA** seduces with its feminine lines that combine a harmonious body curving upward to a long cylindrical bar top finish.



CONTENANCE CAPACITY		50 cl	75 cl	150 cl	150 cl
RÉFÉRENCE REFERENCE		5670 ©*	3628 ©	4698 ©	4698 © Sur commande To order
BAGUE FINISH		 Bague Plate FA Plate FA Finish	 Bague Plate FA Plate FA Finish	 Bague Plate FA Plate FA Finish	 Bague Carrée Spéciale Special Carrée Finish
POIDS WEIGHT	(g)	460	620	1179	1181
HAUTEUR TOTALE TOTAL HEIGHT	A (mm)	290.6	330	397.8	400
Ø PIED BASE Ø	B (mm)	60.5	69.1	89	89
Ø ÉPAULE SHOULDER Ø	C (mm)	73.5	84	108.1	108.1
Ø DÉBOUCHAGE ENTRANCE BORE	D (mm)	18.5	18.5	18.5	18.5
TEINTE GLASS COLOUR		● ○	● ○	● ¹ ○	○

*Nous consulter pour toute commande en France

○ : Extra Blanc / Extra White Flint ● : Antique / Antique Green ¹ : Sur commande / To order

© : Modèle déposé "Design Saverglass" / © : Registered "Design Saverglass"

THEOS WINE

SUPER PREMIUM



Volontairement transgressive, la bouteille **THEOS WINE** opère une rupture franche vis à vis des « figures imposées » que sont les silhouettes génériques bordelaises, bourguignonnes ou flûtes. Son design décalé et innovant revendique un nouveau territoire d'expression et de créativité dans le domaine quelque peu figé des bouteilles de vin. Dédié prioritairement aux « Nouveaux Concepts Vins », **THEOS WINE** s'adresse aux néo-consommateurs en quête de repères attractifs, contemporains et intrigants.

Deliberately transgressive, the **THEOS WINE** bottle makes a clean break from the traditional norms represented by generic Bordelaise, Burgundian or Hock shapes. Its innovative and out-of-step design ventures into new creative and expressive territories within the somewhat sedate world of wine bottles. Dedicated to "New Wine Concepts", **THEOS WINE** is aimed at trendy consumers seeking attractive, contemporary and intriguing benchmarks.

THEOS WINE
SUPER PREMIUM

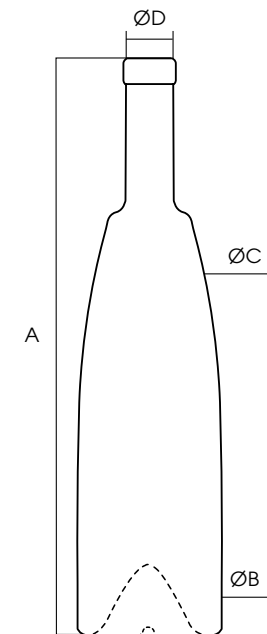

THEOS WINE

CONTENANCE CAPACITY		75 cl
RÉFÉRENCE REFERENCE		3775 ©
BAGUE FINISH		 Bague Plate FA Plate FA Finish
POIDS WEIGHT	(g)	720
HAUTEUR TOTALE TOTAL HEIGHT	A (mm)	325.5
Ø PIED BASE Ø	B (mm)	81.3
Ø ÉPAULE SHOULDER Ø	C (mm)	45.7
Ø DÉBOUCHAGE ENTRANCE BORE	D (mm)	18.5
TEINTE GLASS COLOUR		● ○

○ : Extra Blanc / Extra White Flint ● : Antique / Antique Green

© : Modèle déposé "Design Saverglass" / © : Registered "Design Saverglass"

BORDELAISES ÉCLAT

PREMIUM



BORDELAISES
ÉCLAT
PREMIUM
ORIGINAL DESIGN



Le concept **ÉCLAT** dévoile de nouvelles piqûres conçues pour révéler l'éclat et la brillance du verre Extra Blanc de Saverglass et mettre en valeur les tonalités subtiles et raffinées des vins blancs et des vins rosés. Il est réalisé à partir du modèle Bordelaise **ÉCLAT** qui se distingue par une hauteur de 320 mm en 75 cl, une épaule charnue ainsi qu'une légère conicité du corps et un col effilé. **ÉCLAT** tire également son originalité des six formes de gravure qui favorisent ainsi la concentration de la lumière et révèlent les nuances des robes des différentes cuvées.

The **ÉCLAT** concept unveils new punts designed to showcase the radiance and brilliance of the Saverglass Extra White glass, and to highlight the subtle, refined tonalities of white and rosé wines. It is based on the Bordelaise **ÉCLAT** model, characterized by a height of 320mm in 75cl, a plump shoulder and a slight taper in the body with a long, slim neck. The originality of **ÉCLAT** is enhanced by its six etched motifs, which concentrate light and lend nuance to various wines.

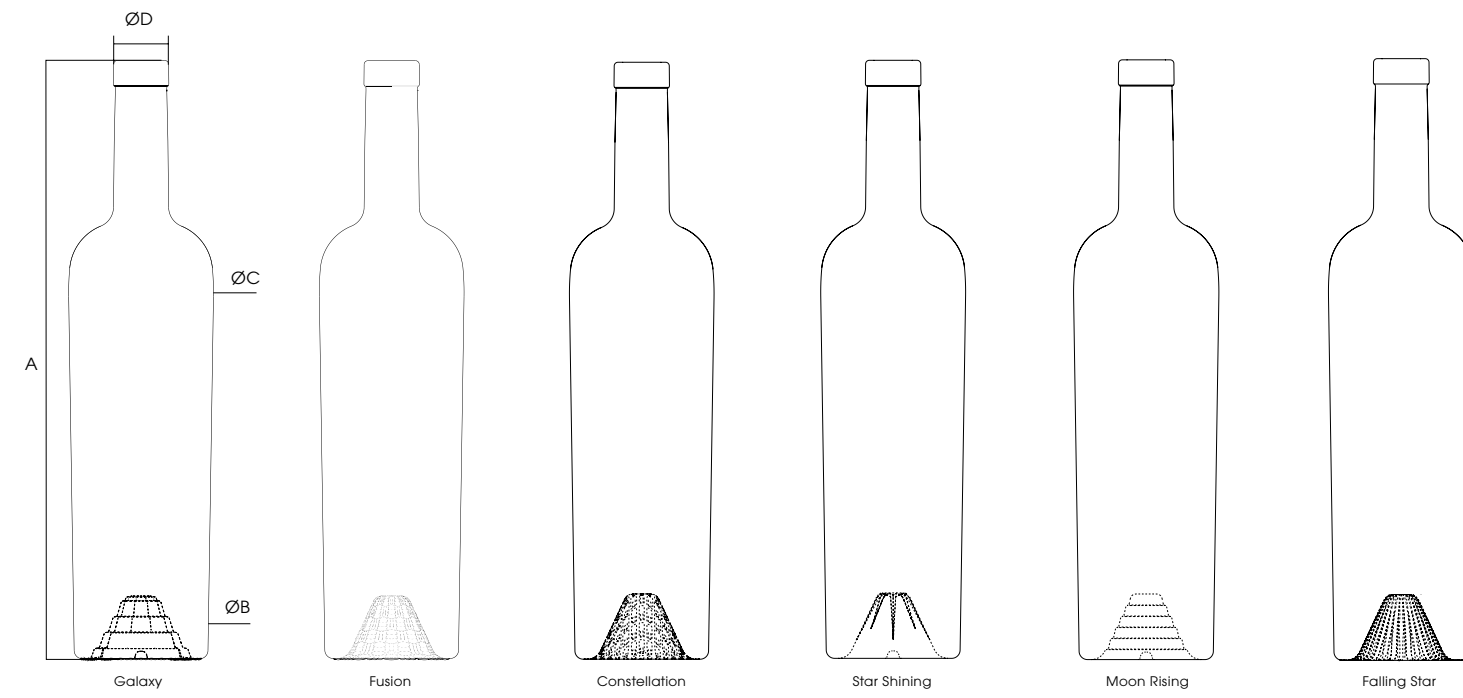

GALAXY **GALAXY** **FUSION** **CONSTELLATION** **CONSTELLATION** **STAR SHINING** **MOON RISING*** **MOON RISING*** **MOON RISING*** **FALLING STAR**

CONTENANCE CAPACITY (cl)		75 cl	150 cl	75 cl	75 cl	150 cl	75 cl	75 cl	150 cl	75 cl
RÉFÉRENCE REFERENCE		5566 ©	5748 ©	5565 ©	5219 ©	5442 ©	5217 ©	5218 ©	5600 ©	5220 ©
BAGUE FINISH		Bague Plate FA Plate FA Finish	Bague Plate FA Plate FA Finish	Bague Plate FA Plate FA Finish	Bague Plate FA Plate FA Finish	Bague Plate FA Plate FA Finish	Bague Plate FA Plate FA Finish	Bague Plate FA Plate FA Finish	Bague Plate FA Plate FA Finish	Bague Plate FA Plate FA Finish
POIDS WEIGHT (g)		600	982	600	600	980	608	600	985	600
HAUTEUR TOTALE TOTAL HEIGHT A (mm)		320	392.2	320	320	392.2	320	320	392.2	320
Ø PIED BASE Ø B (mm)		71.6	88.3	71.6	71.6	88.3	71.6	71.6	88.3	71.6
Ø ÉPAULE SHOULDER Ø C (mm)		77.5	95.8	77.5	77.5	95.8	77.5	77.5	95.8	77.5
Ø DÉBOUCHAGE ENTRANCE BORE D (mm)		18.5	18.5	18.5	18.5	18.5	18.5	18.5	18.5	18.5
TEINTE GLASS COLOUR		○	○	○	○	○	○	○	○	○

○ : Extra Blanc / Extra White Flint

© : Modèle déposé "Design Saverglass" / © : Registered "Design Saverglass"

*Nous consulter pour toute commande en France

BORDELAISES ECLAT PREMIUM

ORIGINAL
DESIGN

CONCEPT INVENT

PREMIUM

ORIGINAL
DESIGN



La ligne **INVENT** propose une « nouvelle piqûre signature » au design avant-gardiste, aux lignes douces qui sculptent avec caractère le fond de la bouteille pour en modifier subtilement le bas-fût tout en préservant l'identité des contenants.

Les modèles Bordelaise et Bourgogne **INVENT** relèvent le défi d'un design responsable : économiser matière et énergie tout en conservant les codes d'expression des grands Bordeaux ou des grands Bourgognes en proposant une hauteur respective de 300 et 296 mm.

The **INVENT** line offers a "new signature punt" with its avant-garde design. Soft lines lend character to the base of the bottle, subtly altering the base while preserving the identity of the content. The Bourgogne and Bordelaise **INVENT** models take up the challenge of eco-responsible design: saving materials and energy while respecting the codes of the great wines of Bordeaux, with heights of 300 and 296mm, respectively.

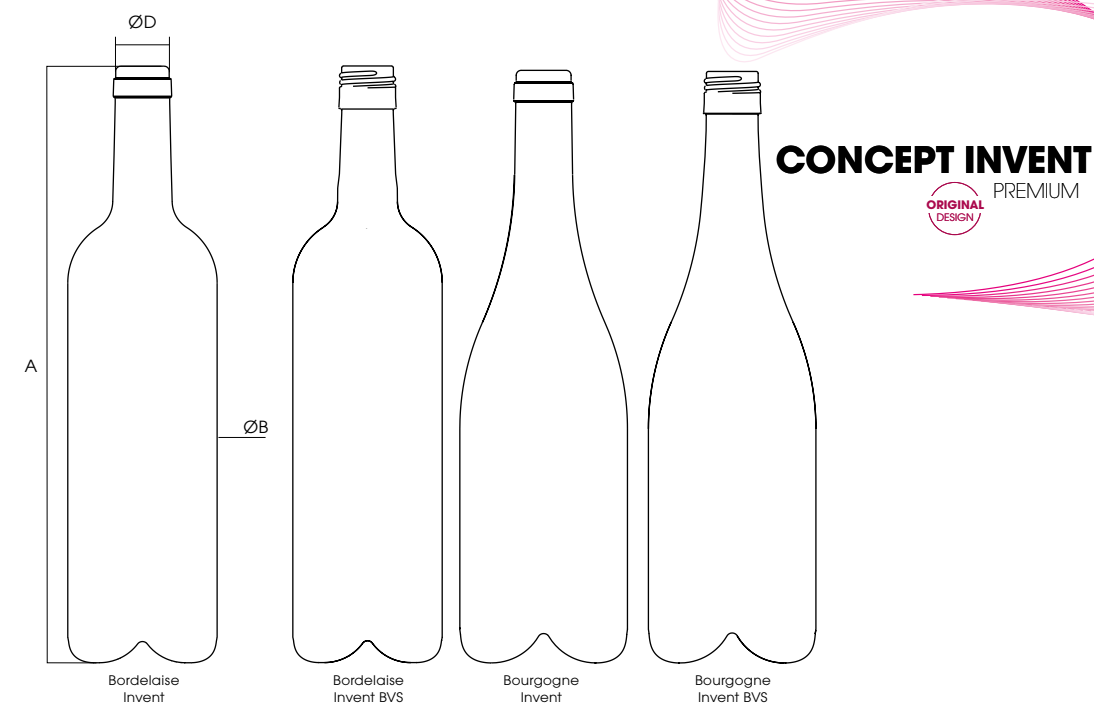

CONTENANCE CAPACITY	75 cl	75 cl	75 cl	75 cl
RÉFÉRENCE REFERENCE	5342 ©	5398 ©	5396 ©	5397 ©
BAGUE FINISH	 Bague Plate Unique Plate Unique Finish	 Bague BVS 30H60 BVS 30H60 Finish	 Bague Plate Unique Plate Unique Finish	 Bague BVS 30H60 BVS 30H60 Finish
POIDS WEIGHT	(g) 507	509	502	507
HAUTEUR TOTALE TOTAL HEIGHT	A (mm) 300	300	296	296
Ø CORPS BODY Ø	B (mm) 75.4	75.4	84	84
Ø DÉBOUCHAGE ENTRANCE BORE	D (mm) 18.5	20	18.5	20
TEINTE GLASS COLOUR	● ○	● ○	● ○	● ○

○ : Extra Blanc / Extra White Flint ● : Antique / Antique Green

© : Modèle déposé "Design Saverglass" / © : Registered "Design Saverglass"

CONCEPT ANTIK

PREMIUM
 PREMIUM DESIGN



Les Bordelaise et Bourgogne **ANTI**K réinterprètent le dessin des modèles en verre soufflés qui contenaient autrefois les grands crus. Revisitant la tradition et s'appuyant sur les technologies verrières de pointe, Saverglass insuffle un vent de modernité et s'inspire du vintage pour créer deux modèles uniques, qui réinterprètent l'icône amphore et offrent une relecture contemporaine des codes de l'authenticité. De hauteur modeste, Bordelaise et Bourgogne **ANTI**K affichent une épaule très marquée et une piqûre avec boudine.

Modélisée sur une qualité de peau de verre d'un raffinement exceptionnel, la Bordelaise **ANTI**K VINTAGE joue la carte d'une patine plus vraie que nature au charme délicieusement suranné.





The Bordelaise and Bourgogne **ANTI**K are reinterpretations of the hand-blown-glass bottles that enclosed the grands crus of yesteryear. Revisiting this tradition and applying the latest glassmaking technologies, Saverglass provides a modern twist inspired by vintage designs to create two unique models that reinterpret the iconic amphora and offer a fresh contemporary approach to authentic codes. Bordelaise and Bourgogne **ANTI**K models are modest in height and boast generous shoulders and a "boudine" in the punt.

Crafted with an exceptionally refined outer glass layer, the Bordelaise **ANTI**K VINTAGE plays up its ultra-natural patina, lending a remarkably antiquated charm.

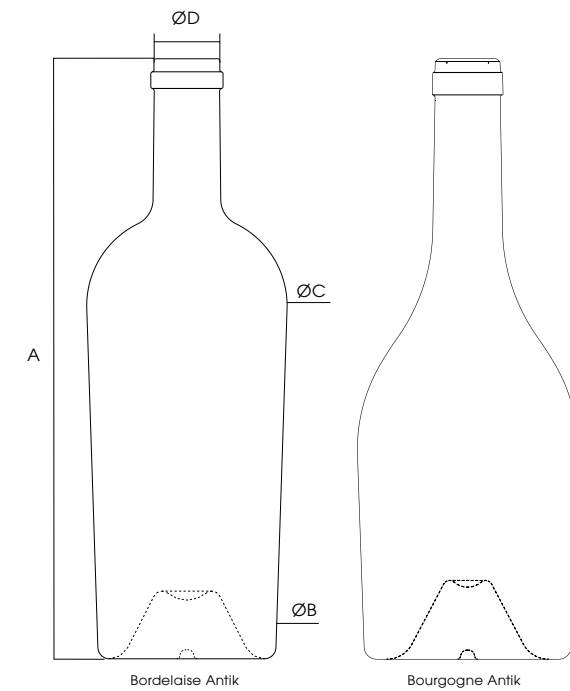
CONCEPT ANTIK

PREMIUM
 PREMIUM DESIGN



CONTENANCE CAPACITY		75 cl	75 cl	75 cl	150 cl
RÉFÉRENCE REFERENCE		5060	5601 Sur commande To order	5564	5697
BAGUE FINISH		 Bague Plate SB29 Plate SB29 Finish	 Bague Plate SB29 Plate SB29 Finish	 Bague Carrée Bourgogne SB29 Carrée Bourgogne SB29 Finish	 Bague Carrée Bourgogne SB29 Carrée Bourgogne SB29 Finish
POIDS WEIGHT	(g)	660	660	629	1120
HAUTEUR TOTALE TOTAL HEIGHT	A (mm)	266	266	267	332.6
Ø PIED BASE Ø	B (mm)	78.9	78.9	92	116.2
Ø ÉPAULE SHOULDER Ø	C (mm)	88.8	88.8	98	123.6
Ø DÉBOUCHAGE ENTRANCE BORE	D (mm)	18.5	18.5	18.5	18.5
TEINTE GLASS COLOUR		● ○	● avec peau de verre aspect vieilli with old-looking aspect	● ○	● ○

○ : Extra Blanc / Extra White Flint ● : Antique / Antique Green

RÉALISATIONS NOUVEAUX CONCEPTS

NEW CONCEPTS PROJECTS



BORDELAISE ANTIK



BORDELAISE INVENT



BORDELAISE ÉCLAT



THEOS WINE



SOPHIA MASSALIA



BOURGOGNE ANTIK



FENG WINE



FLÛTES HOCKS

**ORIGINAL
DESIGN**

FLÛTES ALLEGRO	146
FLÛTES ALTUS	148

**CLASSIC
DESIGN**

FLÛTES ALTUS WINE	150
FLÛTES TRADITION	152
FLÛTES VIN CLUB	154

FLÛTES ALLEGRO

SUPER PREMIUM

ORIGINAL
DESIGN

Une forme pure et tendue, particulièrement longiligne, caractérise la Flûte **ALLEGRO** qui s'inscrit dans les tendances des bouteilles extra hautes. Sa piqûre profonde, en forme d'ogive, renforce l'originalité des flacons et souligne la conicité de son fût.

A simple and straight form, particularly tall and slender, characterizes the Flute **ALLEGRO**, which is part of the extra tall range. Its conical deep punt emphasizes the originality of the bottles and enhances the tapering of the body.

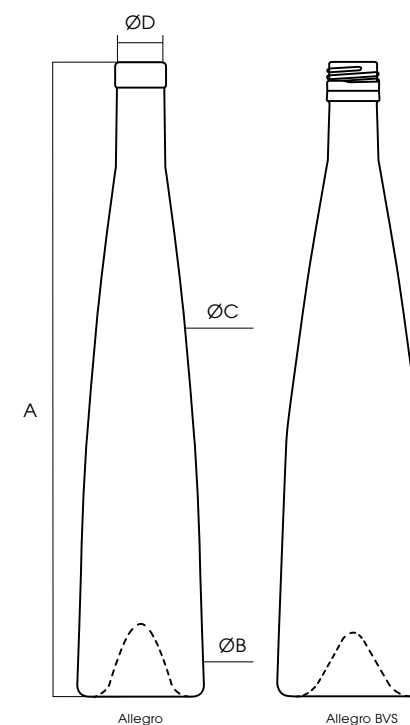



FLÛTES
ALLEGRO
SUPER PREMIUM
ORIGINAL
DESIGN



ALLEGRO

ALLEGRO

ALLEGRO BVS

CONTENANCE CAPACITY		50 cl	75 cl	75 cl
RÉFÉRENCE REFERENCE		2510 ©	2509 ©	4270 © Sur commande To order
BAGUE FINISH		 Bague Plate FA Plate FA Finish	 Bague Plate FA Plate FA Finish	 Bague BVS 30H60 BVS 30H60 FinishBague
POIDS WEIGHT	(g)	560	780	680
HAUTEUR TOTALE TOTAL HEIGHT	A (mm)	350	372	350
Ø PIED BASE Ø	B (mm)	70	82.5	83.1
Ø ÉPAULE SHOULDER Ø	C (mm)	62.8	74.2	74.8
Ø DÉBOUCHAGE ENTRANCE BORE	D (mm)	18.5	18.5	19
TEINTE GLASS COLOUR		● ○ ¹	● ¹ ○	○

○ : Extra Blanc / Extra White Flint ● : Antique / Antique Green ¹ : Sur commande / To order

© : Modèle déposé "Design Saverglass" / © : Registered "Design Saverglass"

FLÛTES ALTUS

SUPER PREMIUM

ORIGINAL
DESIGN



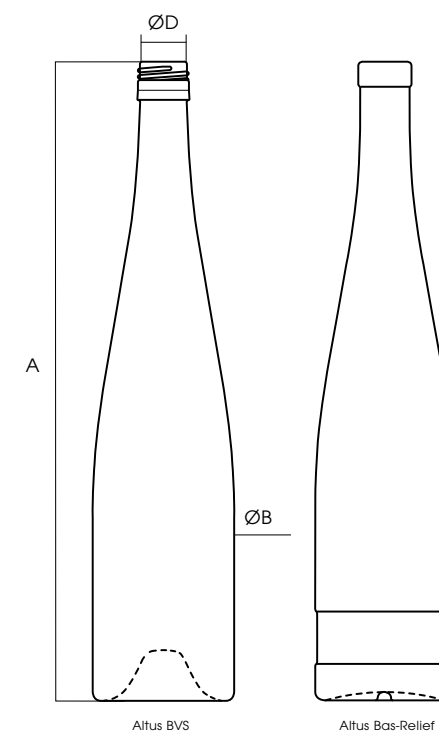

Allure altière et moderne pour la flûte **ALTUS** dont l'esthétique très svelte se prête idéalement à une association avec la bague BVS 30H60. Cette silhouette très pure se décline également dans une version personnalisable : dotée d'une plage circulaire permettant une gravure précise en légère saillie, la Flûte **ALTUS** Bas-Relief offre un support idéal aux options de personnalisation les plus créatives (frise géométrique, texte, scène figurative...).

The Flute **ALTUS** exhibits a proud and modern allure, with its ultra-sleek aesthetic that is ideally suited to the BVS 30H60 screw finish. This very clean silhouette is also available in a personalized version: the heel of the Flûte **ALTUS** has a circular band to enable precise engraving, the ideal backdrop to the most creative personalized options (geometric borders, writing, figurative scenes, etc.).



FLÛTES
ALTUS
SUPER PREMIUM
ORIGINAL
DESIGN



CONTENANCE CAPACITY		37.5 cl	75 cl	75 cl	150 cl
RÉFÉRENCE REFERENCE		3479	3224	2749 Sur commande To order	4937 Sur commande To order
BAGUE FINISH		 Bague BVS 30H60 BVS 30H60 Finish	 Bague BVS 30H60 BVS 30H60 Finish	 Bague Plate FA Plate FA Finish	 Bague BVS 30H60 BVS 30H60 Finish
POIDS WEIGHT	(g)	438	706	660	1256
HAUTEUR TOTALE TOTAL HEIGHT	A (mm)	305	357.3	357.3	478
Ø CORPS BODY Ø	B (mm)	60.7	79.2	77.7	93.5
Ø DÉBOUCHAGE ENTRANCE BORE	D (mm)	20	20	18.5	19
TEINTE GLASS COLOUR		● ○	● ○ ¹	● ●	●

○ : Extra Blanc / Extra White Flint ● : Antique / Antique Green ● : Champagne / Champagne Green ¹ : Sur commande / To order

FLÛTES ALTUS WINE

STANDARD PREMIUM

CLASSIC
DESIGN



FLÛTES
ALTUS WINE
STANDARD PREMIUM

CLASSIC
DESIGN

La gamme **ALTUS WINE** réussit la performance de renouveler avec élégance et simplicité la silhouette traditionnelle de la flûte. Valorisés par une ligne haute très flatteuse, une épaule à peine esquissée et une bague plate, les différents modèles de la gamme brillent par leur tempérament résolument moderne.

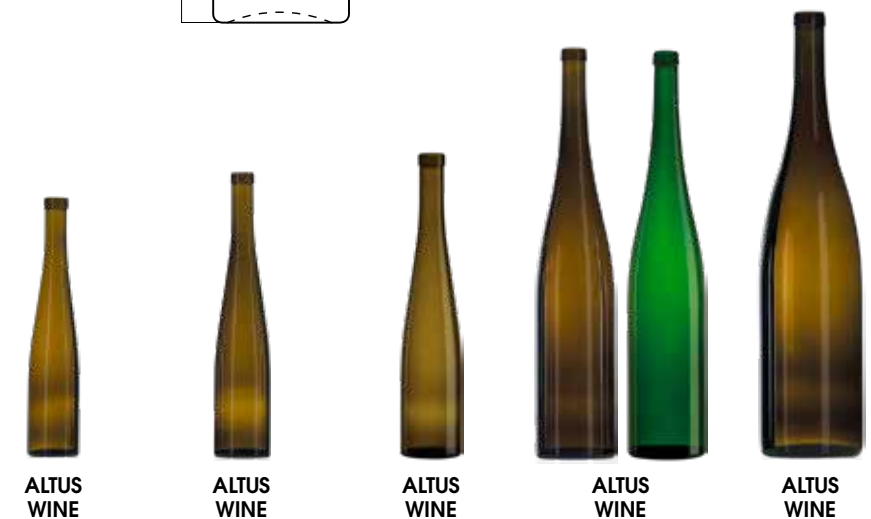
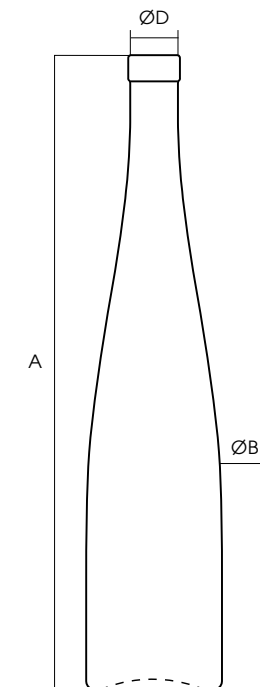
The **ALTUS WINE** range has elegantly and simply updated the traditional hock silhouette. Highlighted by a flattering tall line, a flowing shoulder and a plate finish, the various models in the range shine through their resolutely modern appearance.



CONTENANCE CAPACITY		37.5 cl	50 cl	75 cl	150 cl	300 cl
RÉFÉRENCE REFERENCE		2079	2080	2081	0719	2665 Sur commande To order
BAGUE FINISH		 Bague Plate FA Plate FA Finish	 Bague Plate FA Plate FA Finish	 Bague Plate FA Plate FA Finish	 Bague Plate FA Plate FA Finish	 Bague Plate FA Plate FA Finish
POIDS WEIGHT	(g)	420	538	580	1230	1700
HAUTEUR TOTALE TOTAL HEIGHT	A (mm)	305	336	357.3	478	521.3
Ø CORPS BODY Ø	B (mm)	61.3	68.1	77.7	93.5	121
Ø DÉBOUCHAGE ENTRANCE BORE D (mm)		18.5	18.5	18.5	18.5	24
TEINTE GLASS COLOUR		● ○	● ○	● ○	● ○ ●	●

○ : Extra Blanc / Extra White Flint ● : Antique / Antique Green ● : Champagne / Champagne Green

FLÛTES TRADITION

STANDARD PREMIUM

CLASSIC
DESIGN

La gamme **TRADITION** se compose de flûtes type Alsace permettant d'associer deux principes de bouchage : bague plate unique (type cétie) et bague à vis BVS 30H60 (type Stelvin).

The **TRADITION** range is made up of Alsace type flutes suitable for two capping principles: cétie type and BVS 30H60 screw finish (Stelvin type).

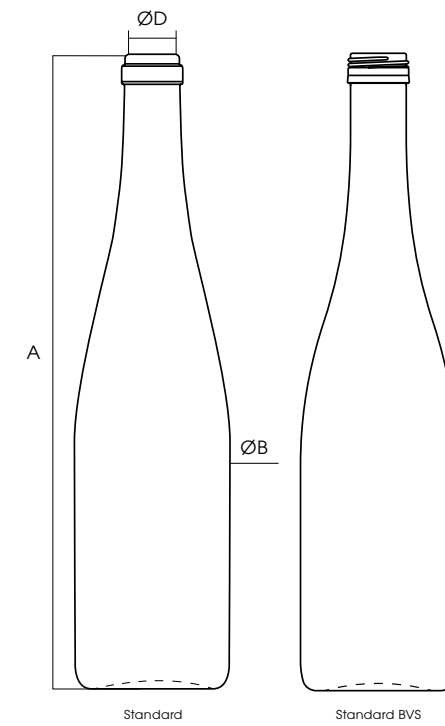

FLÛTES
TRADITION
STANDARD PREMIUM



STANDARD



STANDARD BVS

CONTENANCE
CAPACITY

75 cl

75 cl

RÉFÉRENCE
REFERENCE

T093

3220

BAGUE
FINISH



Bague Plate Unique
Plate Unique Finish



Bague BVS 30H60
BVS 30H60 Finish

POIDS

WEIGHT (g)

535

600

HAUTEUR TOTALE

TOTAL HEIGHT A (mm)

329

329

Ø CORPS

BODY Ø B (mm)

76.9

77.5

Ø DÉBOUCHAGE

ENTRANCE BORE D (mm)

18.5

20

TEINTE

GLASS COLOUR



● : Antique / Antique Green

FLÛTES VIN CLUB

STANDARD PREMIUM

CLASSIC
DESIGN

FLÛTES
VIN CLUB
STANDARD PREMIUM

CLASSIC
DESIGN





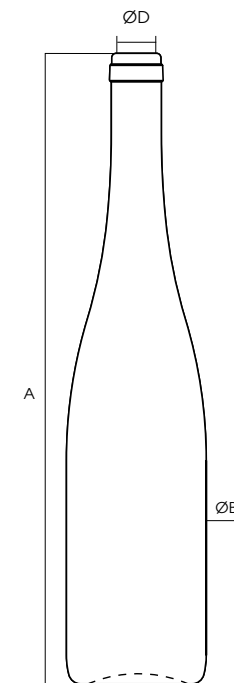

La gamme **VIN CLUB** offre une évolution esthétiquement réussie et maîtrisée de la flûte Alsace traditionnelle. Autre facteur de succès : la diversité des contenances et des teintes proposées.

The **VIN CLUB** range offers an accomplished, elegant and refined evolution in the traditional Alsace hock. The variety of capacities and glass colors offered is another factor that adds to the success of this range.



VIN CLUB VIN CLUB VIN CLUB VIN CLUB VIN CLUB

CONTENANCE CAPACITY	37.5 cl	50 cl	75 cl	150 cl	300 cl
RÉFÉRENCE REFERENCE	1618	1619	1620	0719	2665 Sur commande To order
BAGUE FINISH	 Bague Plate Unique Plate Unique Finish	 Bague Plate Unique Plate Unique Finish	 Bague Plate Unique Plate Unique Finish	 Bague Plate FA Plate FA Finish	 Bague Plate FA Plate FA Finish
POIDS WEIGHT (g)	495	505	650	1230	1700
HAUTEUR TOTALE TOTAL HEIGHT A (mm)	286	310	353	478	521.3
Ø CORPS BODY Ø B (mm)	65.3	69.2	78.3	93.5	121
Ø DÉBOUCHAGE ENTRANCE BORE D (mm)	18.5	18.5	18.5	18.5	24
TEINTE GLASS COLOUR	●	● ○	●	● ○ ●	●

○ : Extra Blanc / Extra White Flint ● : Antique / Antique Green ● : Champagne / Champagne Green



COLLECTION BVS

BORDELAISES BVS	158
BOURGOGNES BVS	160
FLÛTES BVS	162

BVS BORDELAISES



Adaptée aux vins de garde comme aux vins plus jeunes, la capsule à vis offre une étanchéité parfaite, préservant, de fait, le produit des diverses altérations et notamment du risque de goût de bouchon. Respectant les qualités du vin, la bague à vis répond en outre aux nouvelles exigences de commodité des consommateurs. Saverglass propose aujourd'hui une gamme élargie de modèles équipés en bagues à vis, une collection qui s'inscrit dans la démarche de design, de différenciation et de premiumisation initiée depuis longtemps par le groupe Saverglass.

Suitable for young wines as well as those meant for cellaring, the screw cap offers a secure seal, preserving and protecting wines from the numerous problems that impact such a fragile product – including cork taint. By respecting a wine's qualities, screw caps meet the new demands of an expanding market. Saverglass now offers a broader screw finish line, a new twist on the tradition of design, differentiation and premium packaging that have long been the hallmark of the Saverglass Group.

BVS BORDELAISES

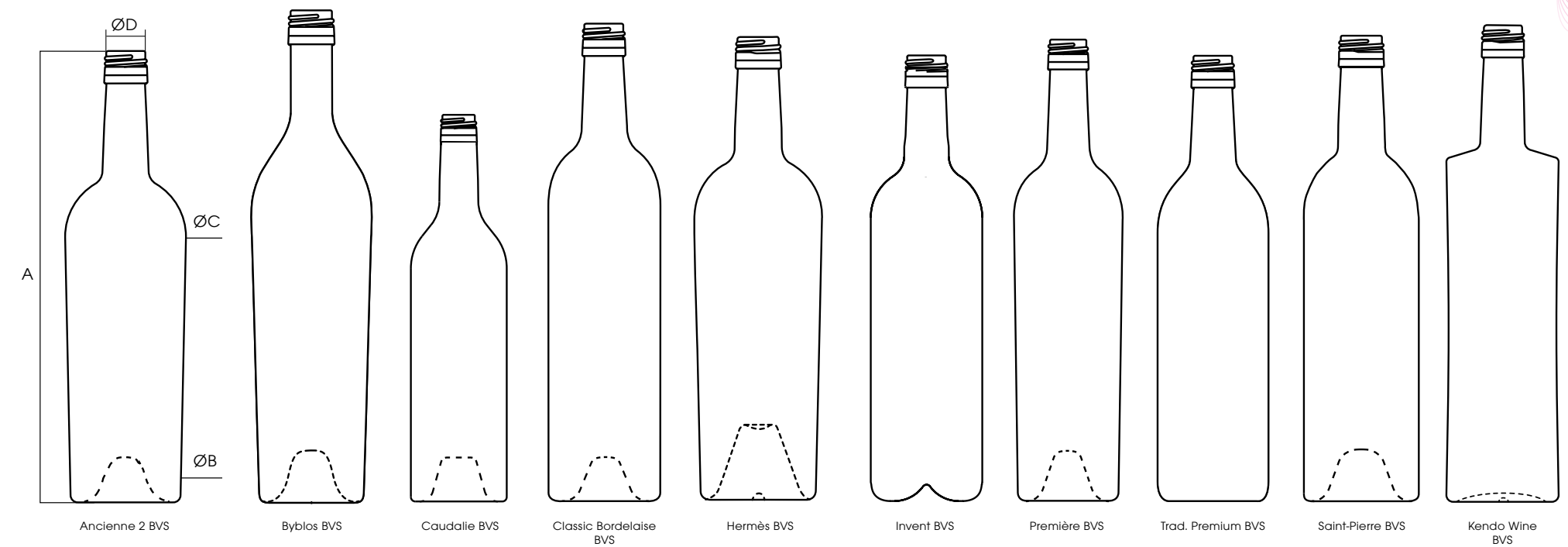

		BVS BORDELAISES												
		Ancienne 2 BVS	Byblos BVS	Caudalie BVS	Classic Bordelaise BVS	Classic Bordelaise BVS	Hermès BVS	Invent BVS	Première BVS	Trad. Premium BVS	Saint-Pierre BVS	Trad. Premium BVS	Trad. Premium BVS	Kendo Wine BVS
CONTENANCE CAPACITY		75 cl	75 cl	75 cl	37.5 cl	75 cl	75 cl	75 cl	75 cl	75 cl	75 cl	75 cl	150 cl	75 cl
RÉFÉRENCE REFERENCE		3407	4051 © Sur commande To order	4518 © Sur commande To order	3451	2987	4048 © Sur commande To order	5398 ©	5352 Sur commande To order	3221	3832 © Sur commande To order	4559	4692 Sur commande To order	3753 ©
BAGUE FINISH														
POIDS WEIGHT	(g)	615	750	600	380	707	998	509	580	715	780	566	1057	706
HAUTEUR TOTALE TOTAL HEIGHT	A (mm)	299	330	300	259	321.3	312.3	300	310	329.5	312	300.5	357	320
Ø PIED BASE Ø	B (mm)	74.1	69.9	77.4	61	75.6	77.8	75.4	76	71.9	78.9	76.6	99.4	75.9
Ø ÉPAULE SHOULDER Ø	C (mm)	81.4	80.5	77.4	61	75.6	86.3	75.4	76	77.9	78.9	76.6	99.4	75.9
Ø DÉBOUCHAGE ENTRANCE BORE D (mm)		20	20.5	20	20	20	20	20	20	20	20.5	19	19	20
TEINTE GLASS COLOUR		●	● ○	●	● ○	● ○	●	● ○	●	● ○ ¹	●	● ○	● ○	● ○

○ : Extra Blanc / Extra White Flint ● : Antique / Antique Green ¹ : Sur commande / To order

© : Modèle déposé "Design Saverglass" / © : Registered "Design Saverglass"

Fonctionnelles par leurs sages mensurations, attractives par leur ligne équilibrée, les Bourgognes BVS prennent en compte les exigences d'aujourd'hui au travers de ce principe de bouchage.

The BVS Burgundian range is both functional with its dimensions, attractive with its well-balanced outline and in harmony with today's demands with its capping principle.

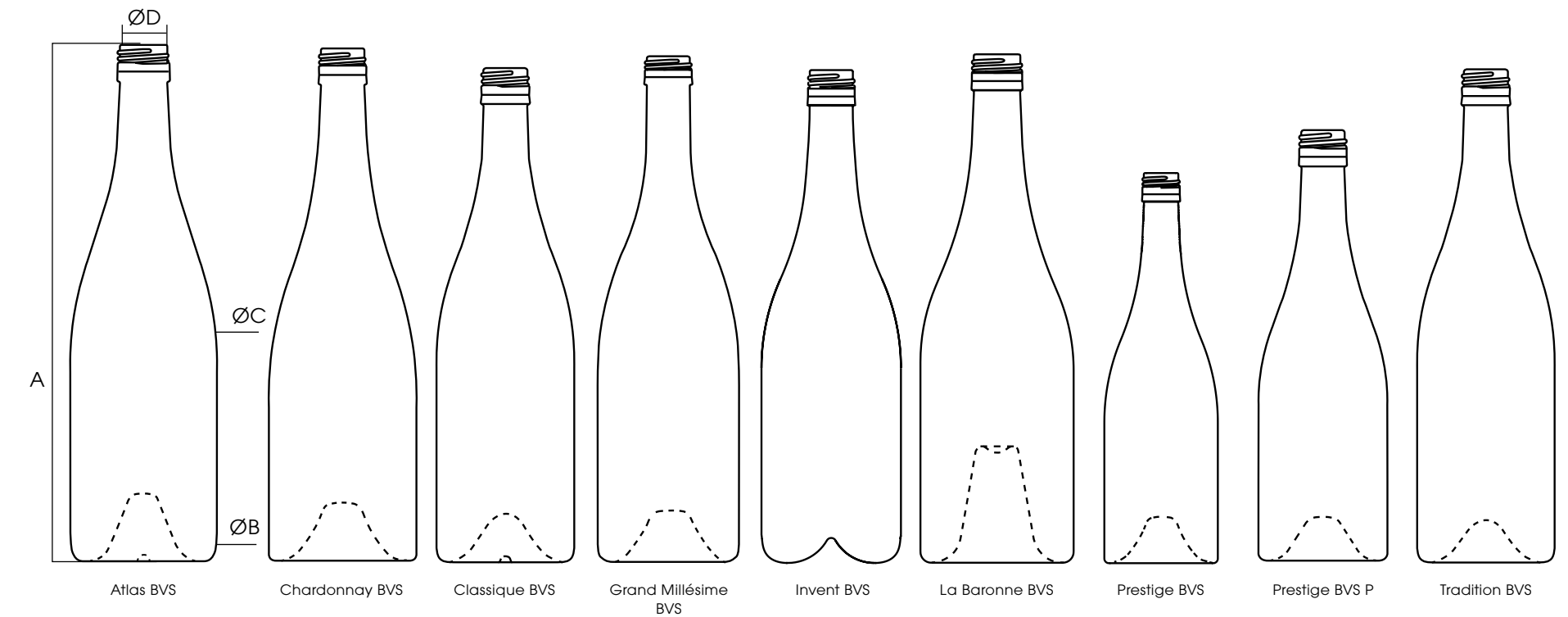

CONTENANCE CAPACITY	75 cl	75 cl	75 cl	75 cl	75 cl	75 cl	75 cl	75 cl	37.5 cl	50 cl	75 cl	150 cl
RÉFÉRENCE REFERENCE	3618 ©	4947 © Sur commande To order	4133 © Sur commande To order	4339 Sur commande To order	2988 ©	5397 ©	4044 © Sur commande To order	5353 Sur commande To order	3649 ©	4340 ©	4413	4833 Sur commande To order
BAGUE FINISH												
POIDS WEIGHT (g)	820	785	865	600	700	507	960	580	437	540	530	1076
HAUTEUR TOTALE TOTAL HEIGHT A (mm)	310	324.7	306	296	303	296	305	295	232.5	258.8	295	354.6
Ø PIED BASE Ø B (mm)	89	83.7	72.3	82.7	85.5	84	92	85.9	72	77.6	82.2	107.5
Ø ÉPAULE SHOULDER Ø C (mm)	89	83.7	86.6	82.7	85.5	84	92	85.9	72	77.6	82.2	107.5
Ø DÉBOUCHAGE ENTRANCE BORE D (mm)	19	19	20.5	20	20	20	20.5	20	20.5	20	20	19
TEINTE GLASS COLOUR	●	●	●	●	●	●○	●	●	●	●	●○	●

○ : Extra Blanc / Extra White Flint ● : Antique / Antique Green

© : Modèle déposé "Design Saverglass" / © : Registered "Design Saverglass"

BVS BOURGOGNES

BVS FLÛTES

La stature imposante des Flûtes et leur ligne fluide et souple, se prêtent idéalement au plan esthétique à l'association avec la bague BVS 30H60.

The impressive status of the Flûtes (hocks) and their flowing, soft silhouette and attractive design are ideally suited to the BVS 30H60 screw finish.

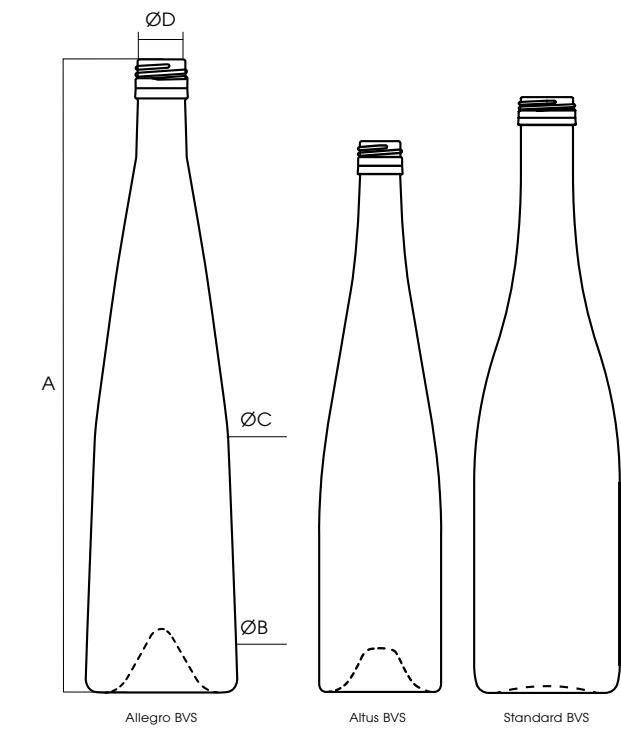

CONTENANCE CAPACITY		75 cl	37.5 cl	75 cl	150 cl	75 cl
RÉFÉRENCE REFERENCE		4270 © Sur commande To order	3479	3224	4937 Sur commande To order	3220
BAGUE FINISH		 Bague BVS 30H60 BVS 30H60 Finish	 Bague BVS 30H60 BVS 30H60 Finish	 Bague BVS 30H60 BVS 30H60 Finish	 Bague BVS 30H60 BVS 30H60 Finish	 Bague BVS 30H60 BVS 30H60 Finish
POIDS WEIGHT	(g)	680	438	706	1256	600
HAUTEUR TOTALE TOTAL HEIGHT	A (mm)	350	305	357.3	478	329
Ø PIED BASE Ø	B (mm)	83.1	60.7	79.2	93.5	77.5
Ø ÉPAULE SHOULDER Ø	C (mm)	74.8	60.7	79.2	93.5	77.5
Ø DÉBOUCHAGE ENTRANCE BORE	D (mm)	19	20	20	19	20
TEINTE GLASS COLOUR		○	● ○	● ○ ¹	●	●

○ : Extra Blanc / Extra White Flint ● : Antique / Antique Green ¹ : Sur commande / To order

© : Modèle déposé "Design Saverglass" / © : Registered "Design Saverglass"

VINS EFFERVESCENTS SPARKLING WINES



CUVÉE DES SACRES	166
CHAMPENOISES ANASSA & HÉRITAGE	168
CHAMPENOISES CHORUS & MILLÉSIME	170
CHAMPAGNE GRAND CRU	172
CHAMPENOISE POMPADOUR	174
CHAMPENOISE ARBANE	176



CRÉMANT	178
CRÉMANT PRESTIGE	180
CHAMPENOISE ECO DESIGN	182



CHAMPENOISES AUSTRAL & ORIGIN .	184
CHAMPENOISE VINTAGE	186
CHAMPENOISES STANDARD	188

CUVÉE DES SACRES

EXTRA PREMIUM



Digne héritière de la tradition Champenoise, la bouteille **CUVÉE DES SACRES** revendique les signes distinctifs des flacons d'exception d'autrefois : silhouette trapue et galbée, fût conique, épaule basse et profil de piqûre facilitant le service du sommelier.

The **CUVÉE DES SACRES** bottle is the rightful heir to the distinction associated with the best examples of champagne bottles from times gone by: a sturdy, curvaceous outline, tapering heel, low shoulder and substantial punt for ease of handling when pouring.

CUVÉE
DES SACRES
EXTRA PREMIUM
ORIGINAL
DESIGN

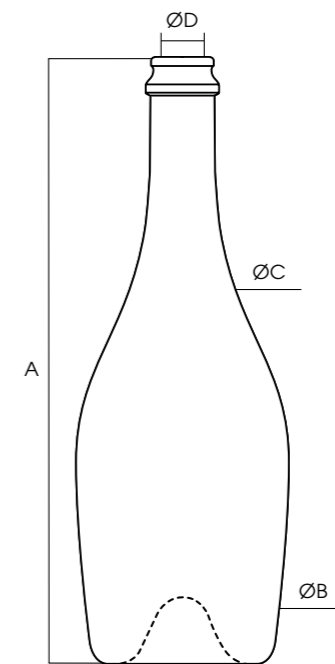

CONTENANCE CAPACITY		75 cl	150 cl	300 cl	300 cl
RÉFÉRENCE REFERENCE		0420 ©	2709 ©	2710 © Sur commande To order	2710 ©
BAGUE FINISH		 Bague Couronne Champ. 29 Couronne Champ. 29 Finish	 Bague Couronne Champ. 29 Couronne Champ. 29 Finish	 Bague Carrée 36 Carrée 36 Finish	 Bague Couronne Champ. 36 Couronne Champ. 36 Finish
POIDS WEIGHT	(g)	900	1750	2925	2925
HAUTEUR TOTALE TOTAL HEIGHT	A (mm)	285	355.4	440	436.2
Ø PIED BASE Ø	B (mm)	87.9	111	137	137
Ø ÉPAULE SHOULDER Ø	C (mm)	100	126.7	156.4	156.4
Ø DÉBOUCHAGE ENTRANCE BORE	D (mm)	17.5	17.5	19	17.5
TEINTE GLASS COLOUR		●	●	●	●

● : Antique / Antique Green

© : Modèle déposé "Design Saverglass" / © : Registered "Design Saverglass"

CHAMPENOISES ANASSA & HÉRITAGE

EXTRA PREMIUM



CHAMPENOISES
ANASSA & HÉRITAGE
EXTRA PREMIUM
ORIGINAL DESIGN

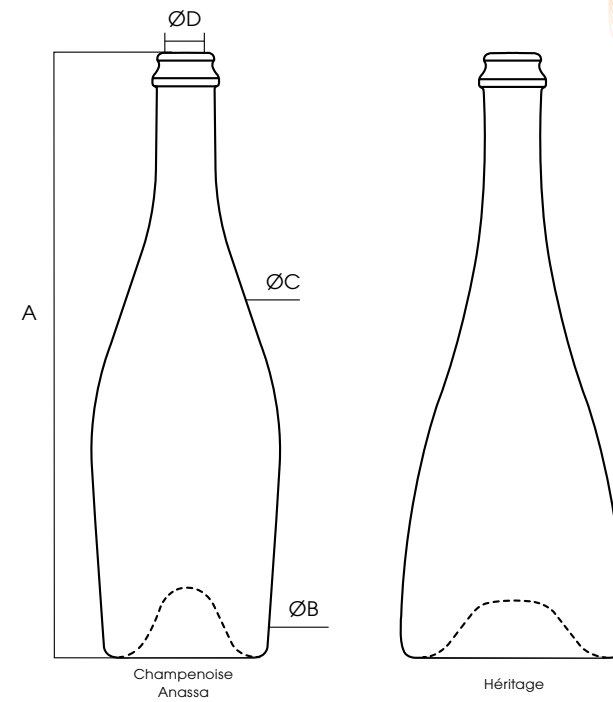

La silhouette d'**ANASSA** s'affranchit des traditions et séduit par un bas-fût conique, un très bel arrondi d'épaule ainsi qu'un col qui participent à l'impression de sveltesse proposée par ce modèle.

Le modèle **HÉRITAGE** transgresse davantage les codes, misant sur le contraste entre la finesse de son col et l'ampleur évasée du bas-fût, offrant ainsi une conicité inversée des plus originales.



The **ANASSA** silhouette breaks with tradition with its seductive tapered based, attractive curved shoulder and a neck that contributes to the slenderness of this model's design.

The **HÉRITAGE** model represents a deeper transgression of traditional codes, highlighting the contrast between the slim elegance of its neck and the flared breadth of its base, offering one of the most original inverse tapers.



ANASSA

HÉRITAGE

CONTENANCE CAPACITY		75 cl	75 cl
RÉFÉRENCE REFERENCE		3833 ©	2646 ©
BAGUE FINISH		 Bague Couronne Champ. 29 Couronne Champ. 29 Finish	 Bague Couronne Champ. 29 Couronne Champ. 29 Finish
POIDS WEIGHT	(g)	920	940
HAUTEUR TOTALE TOTAL HEIGHT	A (mm)	305	300
Ø PIED BASE Ø	B (mm)	82.6	111
Ø ÉPAULE SHOULDER Ø	C (mm)	95	-
Ø DÉBOUCHAGE ENTRANCE BORE	D (mm)	17.5	17.5
TEINTE GLASS COLOUR		● ○	● ○ ¹

○ : Extra Blanc / Extra White Flint ● : Antique / Antique Green ¹ : Sur commande / To order

© : Modèle déposé "Design Saverglass" / © : Registered "Design Saverglass"

CHAMPENOISES CHORUS & MILLÉSIME

SUPER PREMIUM



CHAMPENOISES
CHORUS & MILLÉSIME
SUPER PREMIUM

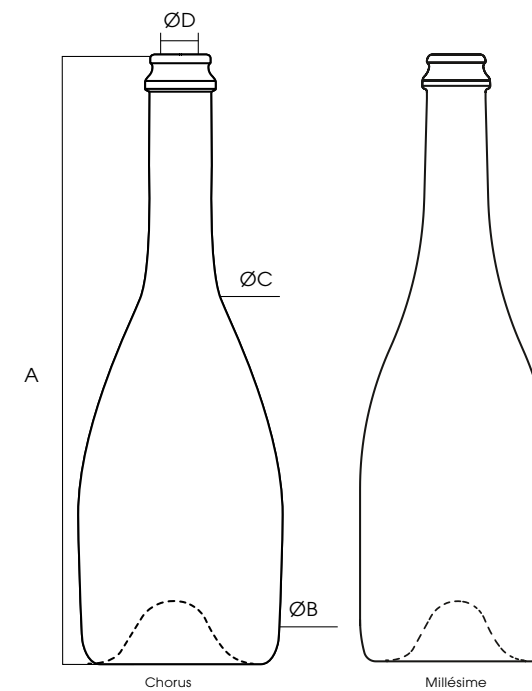

Flacon charismatique pour contenu d'exception, la bouteille **CHORUS** exprime son caractère généreux à travers un corps trapu légèrement conique et une épaule tombante qui vient souligner la spectaculaire finesse du col.

La Champenoise **MILLÉSIME** tire son élégance du contraste saisissant d'un corps opulent, prolongé d'une épaule galbée, avec un col fin et long. Ses sages mensurations et son fût cylindrique en font un contenant fort apprécié des manipulateurs.

A seductive bottle to match its contents, **CHORUS** stands out with its generous lines, stocky slightly tapering body and sloping shoulder to accentuate the finesse of the neck design.



The elegance of Champenoise **MILLÉSIME** stems from the striking contrast of an opulent body, extending into a curved shoulder and a long thin neck. Its sober dimensions and its cylindrical body, make it a container much appreciated by those handling it.



CHORUS



MILLÉSIME

CONTENANCE CAPACITY		75 cl	75 cl
RÉFÉRENCE REFERENCE		2392 ©	T101 ©
BAGUE FINISH		 Bague Couronne Champ. 29 Couronne Champ. 29 Finish	 Bague Couronne Champ. 29 Couronne Champ. 29 Finish
POIDS WEIGHT	(g)	930	890
HAUTEUR TOTALE TOTAL HEIGHT	A (mm)	300.5	300
Ø PIED BASE Ø	B (mm)	98.6	95.1
Ø ÉPAULE SHOULDER Ø	C (mm)	101.6	95.1
Ø DÉBOUCHAGE ENTRANCE BORE	D (mm)	17.5	17.5
TEINTE GLASS COLOUR		● ○ ¹	● ● ¹

○ : Extra Blanc / Extra White Flint ● : Antique / Antique Green ● : Champagne / Champagne Green ¹ : Sur commande / To order

© : Modèle déposé "Design Saverglass" / © : Registered "Design Saverglass"

CHAMPAGNE GRAND CRU

SUPER PREMIUM







CHAMPAGNE
GRAND CRU
SUPER PREMIUM
ORIGINAL DESIGN

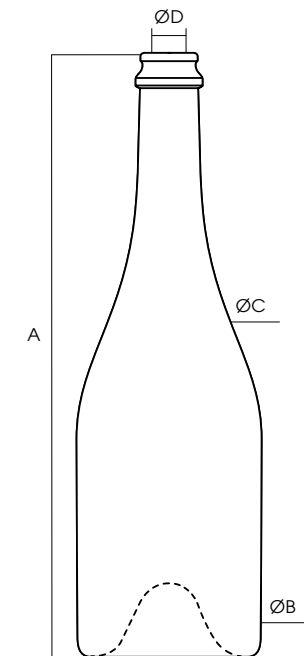

La bouteille Champagne **GRAND CRU** s'est imposée par sa ligne caractéristique comme un conditionnement de prestige. Ses qualités esthétiques et fonctionnelles, ses déclinaisons de teintes et de contenance font de ce modèle la référence des bouteilles de « Cuvées Spéciales ».

Because of its characteristic shape, this Champagne **GRAND CRU** bottle stands out as a Prestige container. Its aesthetic and functional qualities as well as its availability in different glass colors and in a wide range of capacities make it the reference for "Cuvées Spéciales" bottles.



CONTENANCE CAPACITY		37.5 cl	75 cl	150 cl
RÉFÉRENCE REFERENCE		1302 ©	0301 ©	1135 ©
BAGUE FINISH		 Bague Couronne Champ. 29 Couronne Champ. 29 Finish	 Bague Couronne Champ. 29 Couronne Champ. 29 Finish	 Bague Couronne Champ. 29 Couronne Champ. 29 Finish
POIDS WEIGHT	(g)	500	900	1750
HAUTEUR TOTALE TOTAL HEIGHT	A (mm)	242	300	367
Ø PIED BASE Ø	B (mm)	73.8	92.5	120
Ø ÉPAULE SHOULDER Ø	C (mm)	74.8	92.5	120
Ø DÉBOUCHAGE ENTRANCE BORE	D (mm)	17.5	17.5	17.5
TEINTE GLASS COLOUR		●	● ○ ● ¹	●

○ : Extra Blanc / Extra White Flint ● : Antique / Antique Green ● : Champagne / Champagne Green ¹ : Sur commande / To order

© : Modèle déposé "Design Saverglass" / © : Registered "Design Saverglass"

CHAMPENOISE POMPADOUR

SUPER PREMIUM



CHAMPENOISE
POMPADOUR
SUPER PREMIUM
ORIGINAL DESIGN



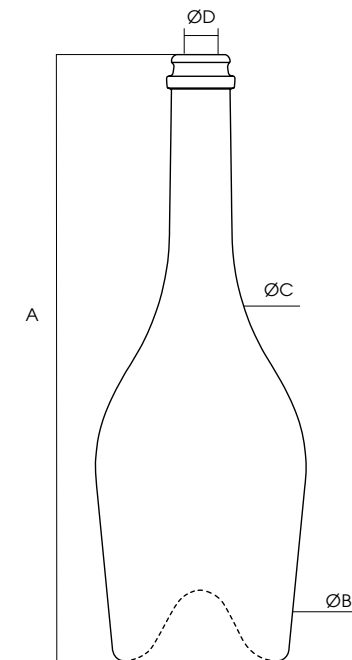

Précieuse, raffinée et féminine, **POMPADOUR** rassure par la douceur de ses formes arrondies et la noblesse de son allure statutaire. Son long col effilé parachève admirablement l'ensemble.

POMPADOUR is a precious, refined and feminine bottle. Its rounded, statuesque body and long slender neck convey true nobility to this model.



POMPADOUR

POMPADOUR

CONTENANCE CAPACITY		75 cl	75 cl
RÉFÉRENCE REFERENCE		4974 ©	4974 ©
BAGUE FINISH		 Bague Couronne Champ. 29 Couronne Champ. 29 Finish	 Bague Couronne & Carrée 29 Couronne & Carrée 29 Finish
POIDS WEIGHT	(g)	940	940
HAUTEUR TOTALE TOTAL HEIGHT	A (mm)	300	300
Ø PIED BASE Ø	B (mm)	86.2	86.2
Ø ÉPAULE SHOULDER Ø	C (mm)	104	104
Ø DÉBOUCHAGE ENTRANCE BORE	D (mm)	17.5	17.5
TEINTE GLASS COLOUR		● ○	● ○

○ : Extra Blanc / Extra White Flint ● : Antique / Antique Green

© : Modèle déposé "Design Saverglass" / © : Registered "Design Saverglass"

CHAMPENOISE ARBANE

PREMIUM ORIGINAL DESIGN

CHAMPENOISE
ARBANE
PREMIUM ORIGINAL DESIGN

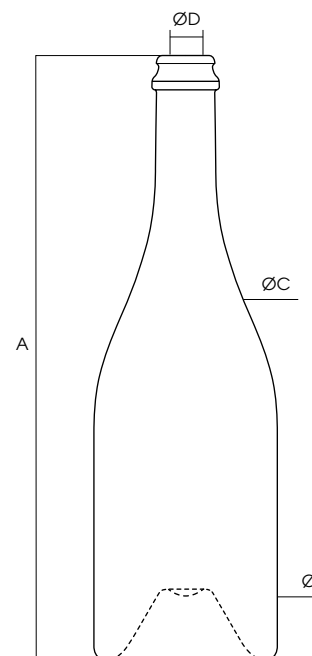



Revisitant sobrement les codes d'expression Champenois, **ARBANE** mise sur l'élégance discrète. Valeur sûre, elle offre raffinement et confort d'utilisation pour une valeur perçue plus élevée.

ARBANE heralds a highly subtle evolution of traditional Champagne codes. It succeeds in conveying a forthright touch of elegance and refinement while offering genuine comfort in its handling and enhancing the image of the bottle.



ARBANE ARBANE ARBANE ARBANE

CONTENANCE CAPACITY		37.5 cl	75 cl	75 cl	150 cl
RÉFÉRENCE REFERENCE		5410 ©	4975 ©	4975 ©	5400 ©
BAGUE FINISH		 Bague Couronne & Carrée 29 Couronne & Carrée 29 Finish	 Bague Couronne Champ. 29 Couronne Champ. 29 Finish	 Bague Couronne & Carrée 29 Couronne & Carrée 29 Finish	 Bague Couronne & Carrée 29 Couronne & Carrée 29 Finish
POIDS WEIGHT	(g)	500	830	830	1750
HAUTEUR TOTALE TOTAL HEIGHT	A (mm)	243	300	300	371.5
Ø CORPS BODY Ø	B (mm)	72.6	91.2	91.2	118.2
Ø DÉBOUCHAGE ENTRANCE BORE	D (mm)	17.5	17.5	17.5	17.5
TEINTE GLASS COLOUR		●	● ○	● ○	● ● ¹

○ : Extra Blanc / Extra White Flint ● : Antique / Antique Green ● : Champagne / Champagne Green ¹ : Sur commande / To order

© : Modèle déposé "Design Saverglass" / © : Registered "Design Saverglass"

CRÉMANT

PREMIUM

PREMIUM DESIGN



Le design de **CRÉMANT PREMIUM** sied idéalement aux vins effervescents et autres méthodes traditionnelles, leur conférant un positionnement packaging haut de gamme. Conditionnement parfait pour ces vins jeunes, très plaisants, aux arômes riches et variés, **CRÉMANT PREMIUM** affiche un poids de verre optimisé à 780 g et une très belle silhouette élancée.

The **CRÉMANT PREMIUM** design is aimed at sparkling and traditional method wines that seek an up-market packaging positioning. **CRÉMANT PREMIUM** provides an ideal backdrop to young and pleasant wines that are rich and varied in aroma, and boasts a glass weight optimized at 780g and a highly attractive slender silhouette.

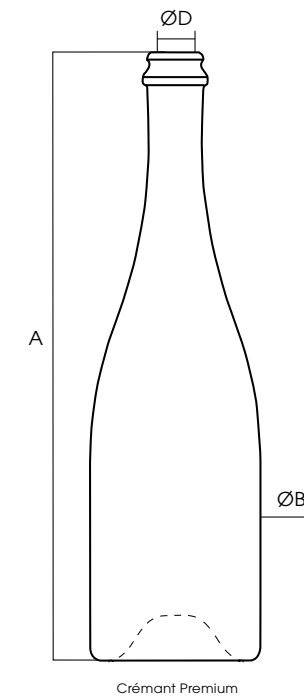

CRÉMANT PREMIUM

CONTENANCE
CAPACITY

75 cl

RÉFÉRENCE
REFERENCE

4574

BAGUE
FINISH



Bague Couronne Champ. 29
Couronne Champ. 29 Finish

POIDS
WEIGHT

(g)

781

HAUTEUR TOTALE
TOTAL HEIGHT

A (mm)

315

Ø CORPS
BODY Ø

B (mm)

88.1

Ø DÉBOUCHAGE
ENTRANCE BORE

D (mm)

17.5

TEINTE
GLASS COLOUR

● ○

○: Extra Blanc / Extra White Flint ●: Antique / Antique Green

CRÉMANT
PREMIUM
PREMIUM DESIGN

CRÉMANT PRESTIGE

PREMIUM
PREMIUM
DESIGN

Réservée à l'élaboration des effervescents et méthodes traditionnelles, le modèle **CRÉMANT PRESTIGE** valorise l'image des vins frais et fruités en quête de positionnement haut de gamme. Doté d'un poids de verre optimisé à 760 g, ce flacon, caractérisé par sa silhouette élégante, habillera les vins avec raffinement.

The **CRÉMANT PRESTIGE** is aimed at the preparation of young, fruity and pleasant wines, sparkling and traditional method wines, which seek an up-market packaging positioning. With a glass weight optimized at 760g, this bottle, characterized by its elegant silhouette with perfect proportions, will show off your wines in a refined way.

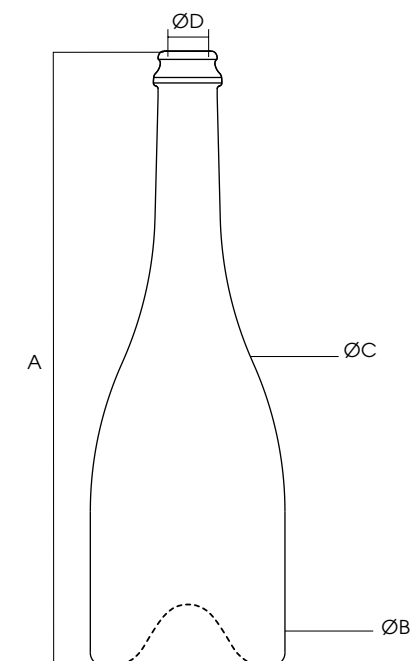

CRÉMANT
PRESTIGE
PREMIUM
PREMIUM
DESIGN



CRÉMANT
PRESTIGE

CONTENANCE
CAPACITY

75 cl

RÉFÉRENCE
REFERENCE

5645

BAGUE
FINISH



Bague Couronne Champ. 29
Couronne Champ. 29 Finish

POIDS
WEIGHT

(g)

760

HAUTEUR TOTALE
TOTAL HEIGHT

A (mm)

300

Ø CORPS
BODY Ø

B (mm)

95.5

Ø DÉBOUCHAGE
ENTRANCE BORE

D (mm)

17.5

TEINTE
GLASS COLOUR

● ○

○: Extra Blanc / Extra White Flint ●: Antique / Antique Green

CHAMPENOISE ECO DESIGN

STANDARD PREMIUM



Déclinée de la version originelle de la Champenoise STANDARD, la Champenoise **ECO DESIGN** propose une version accessible tout en revendiquant un strict respect de la ligne dont elle est issue, la conservation de ses qualités de praticité liées à ses caractéristiques dimensionnelles. Ce modèle se caractérise notamment par un poids modeste de 835 g.

Available as an original version of the Champagne STANDARD bottle, the Champenoise **ECO DESIGN** offers an accessible version while demanding strict adherence to the line from which it hails and the preservation of its convenience-related qualities linked to dimensional features. This model is characterized in particular by its modest weight of 835g.

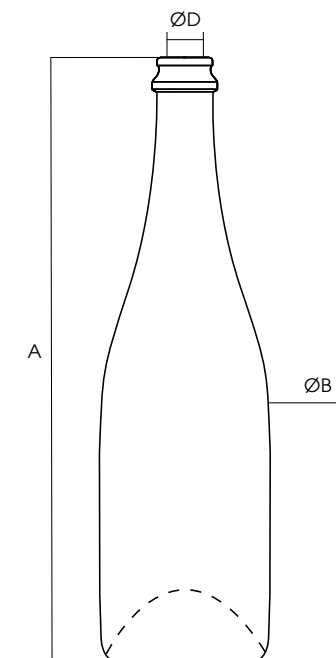

CHAMPENOISE
ECO DESIGN
STANDARD PREMIUM



CHAMPENOISE
ECO DESIGN

CONTENANCE
CAPACITY

75 cl

RÉFÉRENCE
REFERENCE

4435

BAGUE
FINISH



Bague Couronne Champ. 29
Couronne Champ. 29 Finish

POIDS
WEIGHT

(g)

835

HAUTEUR TOTALE
TOTAL HEIGHT

A (mm)

300

Ø CORPS
BODY Ø

B (mm)

88.2

Ø DÉBOUCHAGE
ENTRANCE BORE

D (mm)

17.5

TEINTE
GLASS COLOUR



○ : Extra Blanc / Extra White Flint

● : Antique / Antique Green

● : Champagne / Champagne Green

CHAMPENOISES AUSTRAL & ORIGIN

STANDARD PREMIUM



D'une élégante simplicité, la Champenoise **AUSTRAL** séduit par sa singularité : un corps cylindrique assez trapu souligné par une hauteur de 278,8 mm. Révélant une silhouette sage, au design intemporel, la Champenoise **AUSTRAL** séduira par son élégance et sa grande aisance de manipulation.

Jouant la carte de la sophistication, la Champenoise **ORIGIN** adopte le même dimensionnel que le modèle Champenoise AUSTRAL mais se singularise par deux éléments différenciants : sa bague couronne & carrée et son imposante piqûre avec boudine. Elle affirme ainsi avec audace un tempérament fort et très expressif.

Elegantly simple, the Champenoise **AUSTRAL** seduces with its uniqueness. Its stocky cylindrical body with a height of 278.8mm gives it a unique look compared to the traditional Champagne range. The Champenoise **AUSTRAL** reveals a wise silhouette and timeless design highly appreciated for its elegance and ease of handling.

Playing up its sophistication, Champenoise **ORIGIN** adheres to the same dimensions as Champenoise AUSTRAL yet stands out for two unique elements: its couronne & carrée finish and its deep punt and "boudine" all of which boldly underscore its strong and highly expressive personality.

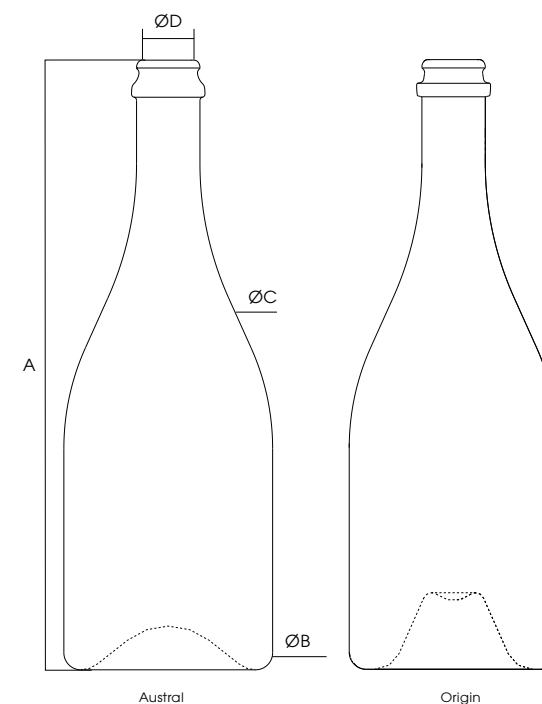



CHAMPENOISES
AUSTRAL & ORIGIN
STANDARD PREMIUM



AUSTRAL



ORIGIN

CONTENANCE CAPACITY		75 cl	75 cl
RÉFÉRENCE REFERENCE		5231 Sur commande To order	5715
BAGUE FINISH		 Bague Couronne Champ. 29 Couronne Champ. 29 Finish	 Bague Couronne & Carrée 29 Couronne & Carrée 29 Finish
POIDS WEIGHT	(g)	890	890
HAUTEUR TOTALE TOTAL HEIGHT	A (mm)	278.8	278.8
Ø CORPS BODY Ø	B (mm)	95.5	95.5
Ø DÉBOUCHAGE ENTRANCE BORE	D (mm)	17.5	17.5
TEINTE GLASS COLOUR		●	●

● : Antique / Antique Green

CHAMPENOISE VINTAGE

STANDARD PREMIUM



La Champenoise **VINTAGE** est un modèle Champenois qui s'inspire des codes d'antan tout en affichant un caractère résolument moderne. Fluidité et élégance caractérisent sa silhouette. Son col long et fin ajoute de la noblesse à ce flacon d'exception. Ses qualités fonctionnelles, son corps cylindrique, ses déclinaisons de teintes, en font le modèle de référence des cuvées Champenoises.

The Champenoise **VINTAGE** model is inspired by the styles of the past while at the same time maintaining a resolutely modern character. Fluidity and elegance characterize the silhouette of Champenoise **VINTAGE**. Its long and thin neck adds a touch of nobility to this exceptional bottle. Its functional qualities, cylindrical body and color range make it the benchmark for the best Vintage Champagnes.

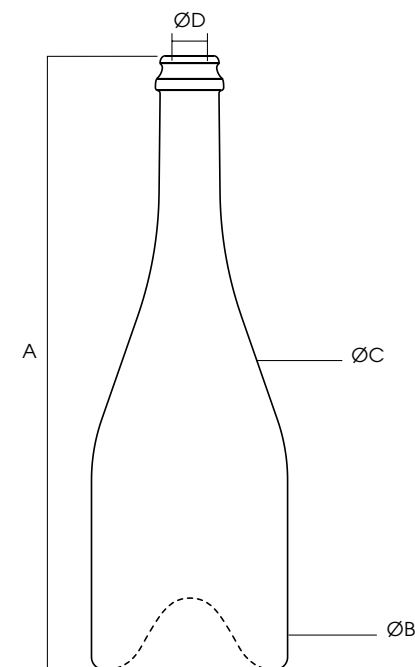

CHAMPENOISE
VINTAGE

STANDARD PREMIUM



VINTAGE

CONTENANCE
CAPACITY

75 cl

RÉFÉRENCE
REFERENCE

5403

BAGUE
FINISH



Bague Couronne Champ. 29
Couronne Champ. 29 Finish

POIDS
WEIGHT

(g)

860

HAUTEUR TOTALE
TOTAL HEIGHT

A (mm)

300

Ø CORPS
BODY Ø

B (mm)

96.5

Ø DÉBOUCHAGE
ENTRANCE BORE

D (mm)

17.5

TEINTE

GLASS COLOUR



○ : Extra Blanc / Extra White Flint ● : Antique / Antique Green ● : Champagne / Champagne Green

CHAMPENOISES STANDARD

STANDARD PREMIUM



CHAMPENOISES
STANDARD
STANDARD PREMIUM



Avec une gamme de contenances qui s'étend depuis le quart jusqu'au format 6 L, le modèle Champenoise **STANDARD** représente un support idéal pour tous les vins effervescents. Un soin particulier est apporté à la disponibilité des teintes autres que la teinte Champagne, telles que l'Antique et l'Extra Blanc, ainsi qu'à des versions de bagues.

The Champenoise **STANDARD** range extends from 20cl to 6L capacities, and represents an ideal model for any sparkling wine. In addition to the Champagne green color, particular care has been taken to provide a wide choice of glass colors, such as Antique Green or Extra White Flint, as well as other finishes.

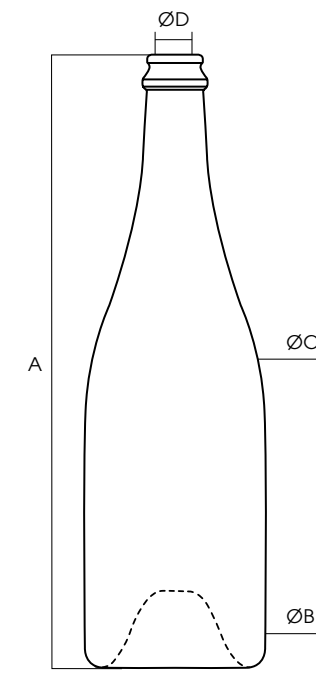

CONTENANCE CAPACITY		20 cl	37.5 cl	75 cl	150 cl	150 cl	300 cl	300 cl	600 cl
RÉFÉRENCE REFERENCE		0729 Sur commande To order	0725	0771	0685	0685 Sur commande To order	0718	0718	1742
BAGUE FINISH		 Bague MCA2 73 MCA2 73 Finish	 Bague Couronne Champ. 29 Couronne Champ. 29 Finish	 Bague Couronne Champ. 29 Couronne Champ. 29 Finish	 Bague Couronne Champ. 29 Couronne Champ. 29 Finish	 Bague Carrée Champenoise Champenoise Carrée Finish	 Bague Couronne Couronne Finish	 Bague Carrée Champ. 36 Carrée Champ. 36 Finish	 Bague Carrée Champenoise Champenoise Carrée Finish
POIDS WEIGHT	(g)	250	500	900	1730	1730	2925	2925	5130
HAUTEUR TOTALE TOTAL HEIGHT	A (mm)	185.7	243.5	300	371.5	371.1	470.3	474.3	571
Ø PIED BASE Ø	B (mm)	58.6	70.6	88.4	114.5	114.5	133.2	133.2	170
Ø ÉPAULE SHOULDER Ø	C (mm)	58.6	70.6	88.4	114.5	114.5	135.2	135.2	174
Ø DÉBOUCHAGE ENTRANCE BORE	D (mm)	17.5	17.5	17.5	17.5	17.5	17.5	19	20.5
TEINTE GLASS COLOUR		○	○ ●	● ○ ● ¹	● ○ ●	●	○ ¹ ●	○ ¹ ●	● ¹ ●

○ : Extra Blanc / Extra White Flint ● : Antique / Antique Green ● : Champagne / Champagne Green ¹ : Sur commande / To order

© : Modèle déposé "Design Saverglass" / © : Registered "Design Saverglass"

CHAMPENOISES
STANDARD
STANDARD PREMIUM

CLASSIC
DESIGN

RÉALISATIONS VINS EFFERVESCENTS

SPARKLING WINES PROJECTS



GRAND CRU



POMPADOUR



HÉRITAGE



ANASSA



CHAMPENOISE
ECO DESIGN

PROFONDEUR DE GAMME RANGE DEPTH

BORDELAISES

NOM / NAME	PAGE	STYLE	STANDING	18.7 cl	20 cl	25 cl	37.5 cl	50 cl	75 cl	150 cl	300 cl	500 cl	600 cl
BORDELAISE 1855	22	ORIGINAL DESIGN	EXTRA PREMIUM						●				
CONSTANCE SUPERBIA	24	ORIGINAL DESIGN	EXTRA PREMIUM						●				
ALEKA	26	ORIGINAL DESIGN	EXTRA PREMIUM						●				
PARADIS	26	ORIGINAL DESIGN	EXTRA PREMIUM						●				
GRAND APPARAT	26	ORIGINAL DESIGN	EXTRA PREMIUM						●				
VINO SANTO	26	ORIGINAL DESIGN	EXTRA PREMIUM						●				
HERMÈS	28	ORIGINAL DESIGN	EXTRA PREMIUM						●				
MERCURE	28	ORIGINAL DESIGN	EXTRA PREMIUM						●				
ALIÉNOR	30	ORIGINAL DESIGN	SUPER PREMIUM					●	●				
APPARAT	32	ORIGINAL DESIGN	SUPER PREMIUM						●				
CORPORATE	32	ORIGINAL DESIGN	SUPER PREMIUM						●				
BELLISSIMA WINE	34	ORIGINAL DESIGN	SUPER PREMIUM	●	●	●	●	●	●	●			
BYBLOS	36	ORIGINAL DESIGN	SUPER PREMIUM						●				
CONSTANCE	38	ORIGINAL DESIGN	SUPER PREMIUM						●				
ICARO	40	ORIGINAL DESIGN	SUPER PREMIUM					●	●	●			
PREMIÈRE ÉCUSSONNÉE	42	ORIGINAL DESIGN	SUPER PREMIUM						●				
CHÂTEAU ÉCUSSONNÉE	42	ORIGINAL DESIGN	SUPER PREMIUM						●				
TRAD. PREMIUM ÉCUSSONNÉE	42	ORIGINAL DESIGN	SUPER PREMIUM						●				
SAINT-PIERRE	44	ORIGINAL DESIGN	SUPER PREMIUM						●	●			
ALIÉNOR 2	46	ORIGINAL DESIGN	PREMIUM						●	●			
ICON	46	ORIGINAL DESIGN	PREMIUM						●	●			
SIGNATURE	48	ORIGINAL DESIGN	PREMIUM					●	●	●			
ANCIENNE	50	PREMIUM DESIGN	PREMIUM						●	●			
CAPRI	52	PREMIUM DESIGN	PREMIUM						●	●			
CAUDALIE	54	PREMIUM DESIGN	PREMIUM						●				
EDEN	56	PREMIUM DESIGN	PREMIUM						●				
MAESTRIA	58	PREMIUM DESIGN	PREMIUM						●				
VINTAGE DOURO	60	PREMIUM DESIGN	PREMIUM						●				
VINTAGE PORTO	60	PREMIUM DESIGN	PREMIUM						●				
RIVIERA	62	PREMIUM DESIGN	PREMIUM						●	●			
ANCIENNE 2	64	PREMIUM DESIGN	STANDARD PREMIUM						●				
SANTIAGO	66	PREMIUM DESIGN	STANDARD PREMIUM						●				
BAMBOO WINE	68	CLASSIC DESIGN	STANDARD PREMIUM					●	●				
CAPRICE	70	CLASSIC DESIGN	STANDARD PREMIUM						●				
CHÂTEAU	70	CLASSIC DESIGN	STANDARD PREMIUM						●				
CLASSIC BORDELAISE	72	CLASSIC DESIGN	STANDARD PREMIUM				●	●	●				
PREMIÈRE	74	CLASSIC DESIGN	STANDARD PREMIUM				●	●	●	●	●		
AVANT-PREMIÈRE	74	CLASSIC DESIGN	STANDARD PREMIUM						●				
TRAD. PREMIUM	76	CLASSIC DESIGN	STANDARD PREMIUM				●		●	●			
TRADITION	76	CLASSIC DESIGN	STANDARD PREMIUM						●	●	●	●	

BOURGOGNES

NOM / NAME	PAGE	STYLE	STANDING	18.7 cl	20 cl	25 cl	37.5 cl	50 cl	75 cl	150 cl	300 cl	500 cl	600 cl
BOURGOGNE 1859	82	ORIGINAL DESIGN	EXTRA PREMIUM							●	●		
LA DIVINE	84	ORIGINAL DESIGN	EXTRA PREMIUM							●			
LA BARONNE	84	ORIGINAL DESIGN	EXTRA PREMIUM							●			
BOURGEOISE	86	ORIGINAL DESIGN	SUPER PREMIUM							●			
CÉLESTE	88	ORIGINAL DESIGN	SUPER PREMIUM							●			
MAXIMA	90	ORIGINAL DESIGN	SUPER PREMIUM							●	●	●	
SABINE	92	ORIGINAL DESIGN	SUPER PREMIUM							●			
DIANE	94	ORIGINAL DESIGN	SUPER PREMIUM							●			
ANASSA	94	ORIGINAL DESIGN	SUPER PREMIUM							●			
MARQUISE	94	ORIGINAL DESIGN	SUPER PREMIUM							●			
CÉPAGE ÉCUSSONNÉE	96	ORIGINAL DESIGN	SUPER PREMIUM							●			
CÉPAGE BAS-RELIEF	96	ORIGINAL DESIGN	SUPER PREMIUM							●			
TASTEVINE ÉCUSSONNÉE	96	ORIGINAL DESIGN	SUPER PREMIUM							●			
CHARDONNAY	98	ORIGINAL DESIGN	PREMIUM							●			
ATLAS BVS	98	ORIGINAL DESIGN	PREMIUM							●			
GRAVILLE	100	PREMIUM DESIGN	PREMIUM							●			
JUSTINE	102	PREMIUM DESIGN	PREMIUM							●			
TASTEVINE	104	PREMIUM DESIGN	PREMIUM							●	●		
VIN GRAND CRU	106	PREMIUM DESIGN	PREMIUM							●	●		
CÉPAGE	108	CLASSIC DESIGN	STANDARD PREMIUM							●			
AGAPE	108	CLASSIC DESIGN	STANDARD PREMIUM				●			●	●		
ÉLÉGANCE	110	CLASSIC DESIGN	STANDARD PREMIUM							●			
GRAND MILLÉSIME	112	CLASSIC DESIGN	STANDARD PREMIUM							●			
PRESTIGE	114	CLASSIC DESIGN	STANDARD PREMIUM				●	●					
SAINT-YVES	114	CLASSIC DESIGN	STANDARD PREMIUM							●			
CADETTE	116	CLASSIC DESIGN	STANDARD PREMIUM							●			
TRADITION	116	CLASSIC DESIGN	STANDARD PREMIUM							●	●	●	●
CLASSIQUE	116	CLASSIC DESIGN	STANDARD PREMIUM							●			

NOUVEAUX CONCEPTS NEW CONCEPTS

NOM / NAME	PAGE	STYLE	STANDING	18.7 cl	20 cl	25 cl	37.5 cl	50 cl	75 cl	150 cl	300 cl	500 cl	600 cl
ESSENCIA WINE	122	ORIGINAL DESIGN	SUPER PREMIUM							●	●		
FENG WINE	124	ORIGINAL DESIGN	SUPER PREMIUM							●			
GEISHA WINE	126	ORIGINAL DESIGN	SUPER PREMIUM							●			
KENDO WINE	128	ORIGINAL DESIGN	SUPER PREMIUM				●			●			
MASSALIA	130	ORIGINAL DESIGN	SUPER PREMIUM							●			
SOPHIA	132	ORIGINAL DESIGN	SUPER PREMIUM					●		●			
THEOS WINE	134	ORIGINAL DESIGN	SUPER PREMIUM							●			
BORD. ÉCLAT GALAXY	136	ORIGINAL DESIGN	PREMIUM							●	●		
BORD. ÉCLAT FUSION	136	ORIGINAL DESIGN	PREMIUM							●			
BORD. ÉCLAT CONSTELLATION	136	ORIGINAL DESIGN	PREMIUM							●	●		
BORD. ÉCLAT STAR SHINING	136	ORIGINAL DESIGN	PREMIUM							●			
BORD. ÉCLAT MOON RISING	136	ORIGINAL DESIGN	PREMIUM							●	●		
BORD. ÉCLAT FALLING STAR	136	ORIGINAL DESIGN	PREMIUM							●			
BORDELAISE INVENT	138	ORIGINAL DESIGN	PREMIUM							●			
BOURGOGNE INVENT	138	ORIGINAL DESIGN	PREMIUM							●			
BORDELAISE ANTIK	140	ORIGINAL DESIGN	PREMIUM							●			
BORDELAISE ANTIK VINTAGE	140	ORIGINAL DESIGN	PREMIUM							●			
BOURGOGNE ANTIK	140	ORIGINAL DESIGN	PREMIUM							●	●		

FLÛTES HOCKS

NOM / NAME	PAGE	STYLE	STANDING	18.7 cl	20 cl	25 cl	37,5 cl	50 cl	75 cl	150 cl	300 cl	500 cl	600 cl
ALLEGRO	146	ORIGINAL DESIGN	SUPER PREMIUM					•	•				
ALTUS BVS	148	ORIGINAL DESIGN	SUPER PREMIUM				•	•	•	•			
ALTUS BAS-RELIEF	148	ORIGINAL DESIGN	SUPER PREMIUM					•					
ALTUS WINE STANDARD	150	CLASSIC DESIGN	STANDARD PREMIUM				•	•	•	•	•		
ALTUS WINE STANDARD	152	CLASSIC DESIGN	STANDARD PREMIUM						•				
VIN CLUB	154	CLASSIC DESIGN	STANDARD PREMIUM				•	•	•	•	•		

COLLECTION BVS

NOM / NAME	PAGE	STYLE	STANDING	18.7 cl	20 cl	25 cl	37,5 cl	50 cl	75 cl	150 cl	300 cl	500 cl	600 cl
BORDELAISE HERMÈS BVS	158	ORIGINAL DESIGN	EXTRA PREMIUM						•				
BORDELAISE BYBLOS BVS	158	ORIGINAL DESIGN	SUPER PREMIUM						•				
BORDELAISE SAINT-PIERRE BVS	158	ORIGINAL DESIGN	SUPER PREMIUM						•				
KENDO WINE BVS	158	ORIGINAL DESIGN	SUPER PREMIUM						•				
BORDELAISE INVENT BVS	158	ORIGINAL DESIGN	PREMIUM						•				
BORDELAISE CAUDALIE BVS	158	PREMIUM DESIGN	PREMIUM						•				
BORDELAISE ANCIENNE 2 BVS	158	PREMIUM DESIGN	STANDARD PREMIUM						•				
BORDELAISE PREMIUM PACIFIC BVS	158	PREMIUM DESIGN	STANDARD PREMIUM						•				
CLASSIC BORDELAISE BVS	158	CLASSIC DESIGN	STANDARD PREMIUM				•		•				
BORDELAISE PREMIÈRE BVS	158	CLASSIC DESIGN	STANDARD PREMIUM						•				
BORDELAISE TRAD. PREMIUM BVS	158	CLASSIC DESIGN	STANDARD PREMIUM						•	•			
BOURGOGNE LA BARONNE BVS	160	ORIGINAL DESIGN	EXTRA PREMIUM						•				
BOURGOGNE BOURGEOISE BVS	160	ORIGINAL DESIGN	SUPER PREMIUM						•				
BOURGOGNE ATLAS BVS	160	ORIGINAL DESIGN	PREMIUM						•				
BOURGOGNE CHARDONNAY BVS	160	ORIGINAL DESIGN	PREMIUM						•				
BOURGOGNE INVENT BVS	160	ORIGINAL DESIGN	PREMIUM						•				
BOURGOGNE PREMIUM EPIC BVS	160	CLASSIC DESIGN	PREMIUM						•				
BOURGOGNE CLASSIQUE BVS P	160	CLASSIC DESIGN	STANDARD PREMIUM						•				
BOURGOGNE GRAND MILLÉSIME BVS	160	CLASSIC DESIGN	STANDARD PREMIUM						•				
BOURGOGNE PRESTIGE BVS	160	CLASSIC DESIGN	STANDARD PREMIUM				•	•					
BOURGOGNE TRADITION BVS	160	CLASSIC DESIGN	STANDARD PREMIUM						•	•			
FLÛTE ALLEGRO BVS	162	ORIGINAL DESIGN	SUPER PREMIUM						•				
FLÛTE ALTUS BVS	162	ORIGINAL DESIGN	SUPER PREMIUM				•	•	•	•			
FLÛTE STANDARD BVS	162	CLASSIC DESIGN	STANDARD PREMIUM						•				

VINS EFFERVESCENTS SPARKLING WINES

NOM / NAME	PAGE	STYLE	STANDING	18.7 cl	20 cl	25 cl	37,5 cl	50 cl	75 cl	150 cl	300 cl	500 cl	600 cl
CUVÉE DES SACRES	166	ORIGINAL DESIGN	EXTRA PREMIUM						•	•	•		
ANASSA	168	ORIGINAL DESIGN	EXTRA PREMIUM						•				
HÉRITAGE	168	ORIGINAL DESIGN	EXTRA PREMIUM						•				
CHORUS	170	ORIGINAL DESIGN	SUPER PREMIUM						•				
MILLÉSIME	170	ORIGINAL DESIGN	SUPER PREMIUM						•				
CHAMPAGNE GRAND CRU	172	ORIGINAL DESIGN	SUPER PREMIUM				•		•	•			
POMPADOUR	174	ORIGINAL DESIGN	SUPER PREMIUM						•				
ARBANE	176	ORIGINAL DESIGN	PREMIUM				•		•	•			
CRÉMANT PREMIUM	180	PREMIUM DESIGN	PREMIUM						•				
CRÉMANT PRESTIGE	182	PREMIUM DESIGN	PREMIUM						•				
CHAMPENOISE ECO DESIGN	178	PREMIUM DESIGN	STANDARD PREMIUM						•				
AUSTRAL	184	CLASSIC DESIGN	STANDARD PREMIUM						•				
ORIGIN	184	CLASSIC DESIGN	STANDARD PREMIUM						•				
VINTAGE	186	CLASSIC DESIGN	STANDARD PREMIUM						•				
STANDARD	188	CLASSIC DESIGN	STANDARD PREMIUM		•		•		•	•	•		•

BAGUES FINISHES

SAVERGLASS DANS LE MONDE IN THE WORLD

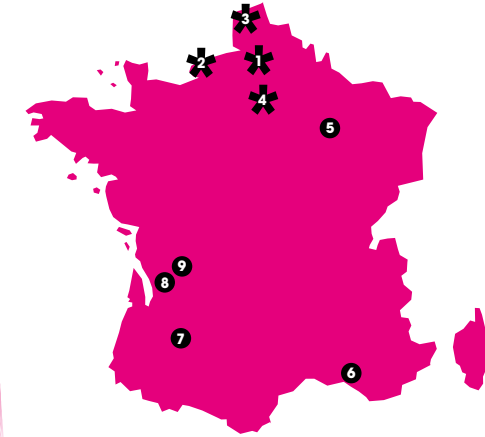

- ★ **USINE VERRE & DÉCOR**
GLASS & DECORATION FACTORY
- **FILIALE / BUREAU**
SUBSIDIARY / OFFICE
- **SHOWROOM**

FRANCE

1-SAVERGLASS
SIÈGE SOCIAL ET USINE
VERRE ET DÉCOR ★■
HEAD OFFICE AND GLASS
AND DECORATION FACTORY
3, rue de la Gare
60960 FEUQUIÈRES
Tel: +33 (0)3 44 46 45 45
Fax: +33 (0)3 44 46 45 00
<http://www.saverglass.com>

2-TOURRES & CIE
USINE VERRE ★
GLASS FACTORY
111, avenue de la Vallée
76600 LE HAVRE

3-ALPHA GLASS-
ALPHADEC
USINE VERRE ET DÉCOR ★
GLASS AND DECORATION
FACTORY
Zone Industrielle du Hocquet
62510 ARQUES

4-SAVERPLUS
USINE DÉCOR ★
DECORATION FACTORY
9-11, rue de l'Aubetin
77120 COULOMMIERS

5-SAVERGLASS
CHAMPAGNE
FILIALE CHAMPENOISE ●
SUBSIDIARY FOR
THE CHAMPAGNE AREA
Pôle d'Activités Saint Julien
Allée Maxenu
51530 PIERRY
Tel: +33 (0)3 26 58 17 85
Fax: +33 (0)3 26 54 77 98
Contact: Stéphane DUBOIS
Valérie ROBINET

6-SAVERSUD
FILIALE ZONE SUD-EST ●
SUBSIDIARY FOR
THE SOUTH-EAST AREA
VenelTech - Bât. A2
994, rue de la Gare
13770 VENELLES
Tel: +33 (0)4 42 90 40 17
Fax: +33 (0)4 42 90 72 88
Contact: Marie CURCI
Laurette HEKIMIAN
Éric JULIEN
Fabien NEVEU

7-VERRERIES & DÉCORS
D'ARMAGNAC (V.D.A.)
FILIALE ZONE SUD-OUEST ●
SUBSIDIARY FOR
THE SOUTH-WEST AREA
Route de Nérac - Z.I.
32100 CONDOM
Tel: +33 (0)5 62 68 30 10
Fax: +33 (0)5 62 28 31 43
Contact: Benoit BARAT
Stéphane GAUTÉ
Philip WALKER

8-SAVERGLASS
COGNAC
FILIALE ZONE COGNAC ●■
SUBSIDIARY FOR
THE COGNAC AREA
Z.I. de Merpins
16100 COGNAC
Tel: +33 (0)5 45 36 69 33
Fax: +33 (0)5 45 36 69 44
Contact: Isabelle ARMAND
Valéry DREVELLE
Stéphane GAUTÉ
Vincent ROBERT

9-SAVERDIS
BUREAU COMMERCIAL
ET DÉPÔT ●
COMMERCIAL OFFICE
AND WAREHOUSE
Z.I. de Merpins
16100 COGNAC
Tel: +33 (0)5 45 82 29 18
Fax: +33 (0)5 45 82 07 52
Contact: Stéphane GAUTÉ
Christine MONNIER
Michelle PRECIGOUT

MONDE WORLD

SAVERGLASS LLC UAE
USINE VERRE ★
GLASS FACTORY
Al Hamra
PO Box 86333
Ras al Khaimah
UNITED ARAB EMIRATES

SAVERGLASS
AUSTRALIA Pty Ltd.
FILIALE AUSTRALIE ●
SUBSIDIARY IN AUSTRALIA
289 Flinders Street,
PO Box 6537 (Halifax street)
Adelaide SA 5000 - AUSTRALIA
Tel: +61 (08) 8232 0770
Fax: +61 (08) 8232 0880
Contact: Sally ARNOLD
Brenton CAMPBELL
Paul PALEOLOGOS

SAVERGLASS IBERICA Ltd.
FILIALE PORTUGAL ●■
SUBSIDIARY IN PORTUGAL
132-134, ed. 2 Portela de
Sintra
2710-418 Sintra - PORTUGAL
Tel: +351 21 924 80 60 61/62
Fax: +351 21 924 80 63
Contact: Bruno de BOTTON
Paulo SAFONT

BUREAU COMMERCIAL
EN ESPAGNE ●
COMMERCIAL OFFICE
IN SPAIN
Plaza Carlos Trias Bertran, 4
1a Planta - «Ibercenter
Business Center»
28020 Madrid - SPAIN
Tel: (+34) 91 418 45 09
Fax: (+34) 91 418 45 29
Contact: Fernando ARAGON
Bruno de BOTTON

SAVERGLASS Inc.
FILIALE ÉTATS-UNIS CÔTE
OUEST ●
SUBSIDIARY IN THE UNITED
STATES WEST COAST
841 Latour Court Suite B
Napa CA 94558 - USA
Tel: +1 (707) 259 29 30
Fax: +1 (707) 259 29 33
Contact: Franck COLLET
Petra GILLIER
Kelly KERBS
Jennifer OLIVER
Jyll VIDAL

SAVERGLASS Inc.
FILIALE ÉTATS-UNIS
MID WEST ●
SUBSIDIARY IN THE UNITED
STATES MID WEST
Louisville KY - USA
Tel: +1 (859) 308 7130
Contact: Franck COLLET
Courtney EHTERTON

SAVERGLASS Inc.
FILIALE ÉTATS-UNIS
CÔTE EST ●■
SUBSIDIARY IN THE UNITED
STATES EAST COAST
107 Spring Street Suite 210
Ramsey NJ 07446 - USA
Tel: +1 (201) 825 7100
Fax: +1 (201) 825 7117
Contact: Franck COLLET
Stéphane STANTON-
BRAND

SAVERGLASS ITALIA Srl.
BUREAU DE REPRÉSENTATION
ITALIE ●■
REPRESENTATIVE OFFICE IN
ITALY
Via Lazzaretto, 19
20124 Milano - ITALIA
Tel: +(39) 024 549 0078
Contact: Pedro ALMEIDA

SAVERGLASS MEXICO
FILIALE AMÉRIQUE LATINE ●
LATIN AMERICAN
SUBSIDIARY
Av. México No. 5000
Calle Fidias 140, Col. Vallarta
San Jorge
Guadalajara, Jalisco
44690 México - MEXICO
Tel: +(52-33) 3123 2033
Fax: +(52-33) 3123 2043
Contact: Sebastian KENTZLER

SAVERGLASS MOSCOU
BUREAU DE REPRÉSENTATION
RUSSIE ●
REPRESENTATIVE OFFICE IN
RUSSIA
Ulitsa Timour Frounze,
d. 22, str. 1, office 4
Moscow, 119021 - RUSSIA
Tel: +7 (499) 245 1760
Fax: +7 (499) 246 5717
Contact: Mickaël JOUHOURIAN
Alina LOBANOVA

SAVERGLASS (NZ) Ltd.
FILIALE NOUVELLE ZÉLANDE ●
SUBSIDIARY IN NEW ZEALAND
Unit G, 383 Khyber Pass Road
Newmarket, Auckland
NEW ZEALAND
Tel: + 64 9 522 2990
Fax: +64 9 522 2994
Contact: Karen BULLEN

SAVERGLASS POLSKA
BUREAU DE REPRÉSENTATION
POLOGNE ●
REPRESENTATION OFFICE IN
POLAND
Spółka Akcyjna Uproszczona
PRZEDSTAWICIELSTWO
W POLSCE
UL. Zurawia 6/12 00-503
Warszawa - POLAND
Tel: +48 (22) 420 33 53
Fax: +48 (22) 420 33 54
Contact: Dorota SZNAJDER

SAVERGLASS Pty Ltd.
FILIALE AFRIQUE DU SUD ●
SUBSIDIARY IN SOUTH AFRICA
P.O. Box 333, Somerset Mall,
7137 Anchor House, Fair ways
Office Park, 5 Niblick Way,
Somerset West, 7130
SOUTH AFRICA
Tel: +27 (021) 851 0005
Fax: +27 (021) 851 0011
Contact: Sandrine CARRY

SAVERGLASS UK
BUREAU COMMERCIAL
ANGLETERRE ●
COMMERCIAL OFFICE IN
ENGLAND
Tel: +44 (0) 113 322 15 95
Contact: Brian CLIFFE
Claire BURNS

SAVERGLASS se réserve le droit de modifier ou de supprimer certains modèles figurant dans les gammes présentées, ou de supprimer certaines versions de teinte ou de bouchage.

Les éléments techniques dans ce catalogue, et notamment les caractéristiques dimensionnelles des articles, n'ont qu'un caractère indicatif. Ils ne peuvent être utilisés en l'état pour la vérification de problème de machinabilité ou pour l'étude d'habillage (étiquetage, bouchage, capsulage, parachèvement,...) et de sur-emballage.

Pour ce faire, SAVERGLASS recommande l'utilisation des plans verriers en vigueur et d'échantillons verre disponibles sur simple demande.

SAVERGLASS est titulaire de tous les droits de propriété intellectuelle (droit d'auteur, dessin, modèle, marque et autres) afférents, relatifs et/ou attachés aux modèles dits « Design Saverglass » et aux modèles personnalisés ou déclinés des modèles « Design Saverglass », ainsi qu'aux articles représentant ou reproduisant ces modèles, ce que reconnaît le Client qui s'interdit de se prévaloir ou de revendiquer un quelconque droit de propriété de la nature de ceux précités sur lesdits modèles, comme de les reproduire ou représenter ou les faire reproduire ou représenter par un tiers, notamment sous forme de cols verriers. SAVERGLASS est également titulaire de tous droits de propriété sur tous les plans, dessins, modèles, maquettes, échantillons, typons, ébauches, croquis, projets, études et autres documents techniques ou artistiques de toute nature qui émanent de sa part et peuvent, dans leurs rapports commerciaux, être adressés au Client. Le Client s'interdit de divulguer ceux-ci comme d'en faire un quelconque usage autre que dans le cadre de ses seuls rapports commerciaux avec SAVERGLASS.

Ce catalogue a été imprimé en juin 2016.

SAVERGLASS reserves the rights to cancel the availability in certain colors of glass or type of finish to modify or remove some of the items which appear in the ranges presented here.

The technical elements detailed in this catalogue and, in particular, the dimensional details of the bottles, are given only as an indication. They cannot be used as such for technical evaluation, for the study of secondary materials (labels, closures, capsules, decoration, etc.) or exterior packaging. For such purposes, SAVERGLASS recommends the use of that full technical designs together with glass samples, which are available on request.

SAVERGLASS is the holder of all intellectual property rights (copyright, design, patent, trademark and others) assignable, relating and/or attached to designs named "Design Saverglass" and to personalised or range extensions of "Design Saverglass" designs, including items representing or reproducing these designs, this is acknowledged by the Customer who shall refrain from exercising or claiming whatsoever right of ownership of the aforementioned nature on the said designs, such as reproducing or representing them or having them reproduced or represented by a third party, specifically in the shape of glass items. SAVERGLASS is also the holder of all property rights for all the plans, drawings, designs, models, samples, typons, rough designs, sketches, projects, studies and other technical or artwork documents of any type coming from them, that may, in the course of commercial dealings, be handed to the Customer. The Customer undertakes not to disclose any of the information or make use of it, other than in the sole context of his commercial dealings with SAVERGLASS.

This catalogue was printed in June 2016.

HAUTE COUTURE **GLASS**

SAVERGLASS

PLACE DE LA GARE
60960 FEUQUIERES FRANCE
Tél. : +33 (0)3 44 46 45 45

www.saverglass.com